

MARONA

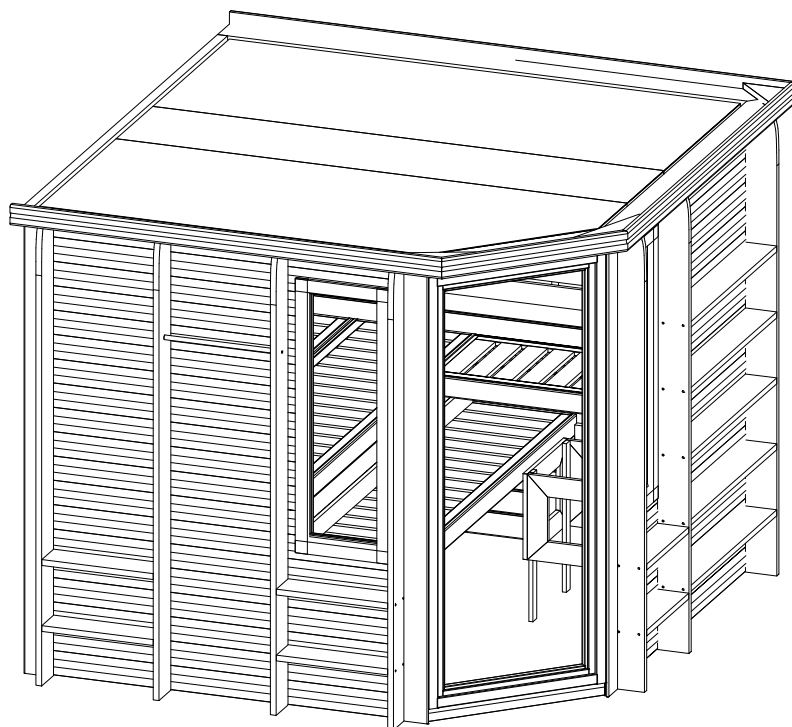

 **Aufbauanleitung**

 **montagehandleiding**







 **notice de montage**



 **Instrucciones de
construcción**



 **Building Instructions**

 **Istruzioni per il
montaggio**

86432-2006-2007

					
<p>Vergleichen Sie zuerst die Materialliste mit Ihrem Paketinhalte! Bitte haben Sie Verständnis, dass Beanstandungen nur im <u>nicht aufgebauten</u> Zustand bearbeitet werden können!</p> <p>Anhand dieser Liste können Sie die Ihnen vorliegenden Elemente und Leisten der Anleitung zuordnen.</p>	<p>Vergelijk eerst de lijst van materialen met de inhoud van uw pakket! Reclamaties kunnen alleen in behandeling worden genomen zolang de onderdelen <u>nog niet gemon-teerd</u> zijn!</p> <p>Aan de hand van deze lijst kunt u de aanwezige elementen en planken met de gebruiksaanwijzing vergelijken.</p>	<p>Veillez d'abord comparer la liste du matériel avec le contenu de votre colis! Nous vous remercions de bien vouloir comprendre que les réclamations ne peuvent être traitées qu'à l'état <u>non monté</u> !</p> <p>À l'aide de cette liste, vous pouvez attribuer à la notice respective les éléments et plinthes dont vous disposez.</p>	<p>En primer lugar, compare la lista de material con el contenido del paquete. Rogamos entienda que las reclamaciones sólo pueden ser tramitadas <u>antes de montar el objeto</u>.</p> <p>En virtud de esta lista, usted puede clasificar los elementos y listones de las instrucciones existentes.</p>	<p>Firstly compare the material list with the contents of your package! Please appreciate that complaints can be processed only in the <u>non-assembled state</u>!</p> <p>Use this list to check off the elements and ledges referred to in the instructions.</p>	<p>Confrontare la distinta dei materiali con il contenuto del pacchetto! Le reclamazioni potranno essere accettate solamente se i prodotti <u>non sono ancora stati montati</u>!</p> <p>Con l'aiuto di questa lista sarà possibile identificare gli elementi ed i listelli delle istruzioni.</p>

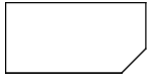
Saunagrundkörper: Saunacabine: Corps de base sauna: Cuerpo base de sauna: Sauna cabin: Cabina della sauna:				Maße in mm Afmetingen in mm Dimensions en mm Dimensiones en mm Dimensions in mm Misure in mm			Modell: Model: Modèle: Modelo: Model: Modello:	
Pos. Pos. Pos. Pos. Pos. Pos.	Nr. Nr. N° N° No. N°	Bezeichnung Benaming Désignation Denominación Description Descrizione	Bild Afbeelding Illustration Dibujo Illustration Immagine	Länge Lengte Long- ueur Longi- tud Length Lungh.	Breite Breedte Largeur Ancho Width Largh.	Stärke Dikte Épais- seur Espesor Thick- ness Spess.	Material Materiaal Matériau Material Material Materiale	Stück Aantal Pièce Ctdad Num- ber Q.tà
20820	1	Wandelement Rückwand Wandelement achterwand Élément mural arrière Elemento de pared posterior Wall element rear wall Elemento parete posteriore		2040	2324	40	Vormontiert Voorgemonteerd Prémonté Premontado pre-assembled Premontato	1
20796	2	Wandelement Seite Wandelement zijkant Élément mural côté Elemento de pared lateral		2040	2324	40	Vormontiert Voorgemonteerd Prémonté Premontado pre-assembled Premontato	1
40609	3	Wandelement side Wandelement zijde Élément mural côté Elemento de pared lateral		2040	1731	40	Vormontiert Voorgemonteerd Prémonté Premontado pre-assembled Premontato	1
20721	4	Wandelement Front Wandelement voorzijde Élément mural façade Elemento de pared delantera Wall element front Elemento parete anteriore		2040	1713	40	Vormontiert Voorgemonteerd Prémonté Premontado pre-assembled Premontato	1
20701	5	Systemleiste Einstieg Systeemplat instap Plinthe système entrée Listón de sistema entrada System ledge entrance Listello ingresso		2040	38	61	Leiste Lat Plinthe Listón Ledge Corrente	2
20634	6	Einstiegsbrett Deurdorpel Planche entrée Tabla de entrada Entrance plank Tavoletta ingresso		810	84	40	Zuschnitt Op maat Découpe Recorte pre-cut part Assi	2

Saunagrundkörper: Saunacabine: Corps de base sauna: Cuerpo base de sauna: Sauna cabin: Cabina della sauna:				Maße in mm Afmetingen in mm Dimensions en mm Dimensiones en mm Dimensions in mm Misure in mm			Modell: Model: Modèle: Modelo: Model: Modello:	86432
Pos. Pos. Pos. Pos. Pos.	Nr. Nr. N° N° No. N°	Bezeichnung Benaming Désignation Denominación Description Descrizione	Bild Afbeelding Illustration Dibujo Illustration Immagine	Länge Lengte Long- ueur Longi- tud Length Lungh.	Breite Breedte Largeur Ancho Width Largh.	Stärke Dikte Épais- seur Espesor Thick- ness Spess.	Material Materiaal Matériau Material Material Materiale	Stück Aantal Pièce Ctdad Num- ber Q.tà
43916	8	Dachplatte Dakplaat Panneau de toit Tablero del techo		2282	904	57	Vormontiert Voorgemonteerd Prémonté Premontado	1
43915	10	Roof plate Tavole del tetto		2282	435	57	pre-assembled Premontato	1
43917	9	Dachplatte schräg Dakplaat afgeschuind Panneau de toit incliné Placa del tejado inclinado Roof plate inclined Tavola obliqua del tetto		2282	904	57	Vormontiert Voorgemonteerd Prémonté Premontado pre-assembled Premontato	1
20527	11	Tür incl. Beschläge Deur incl. hang- en sluitwerk Porte, garnitures comprises Puerta incl. guarniciones Door including fixtures Porta, incl. cerniere		1911	815	40	Vormontiert Voorgemonteerd Prémonté Premontado pre-assembled Premontato	1
20691	20	Deckenleiste		799	28	38	Leiste	1
20700	22	Deklat plafond		2191	28	38	Lat	1
40604	23	Plinthe de plafond		2285	28	38	Plinthe	1
40612	21	Listón del techo		1727	28	38	Listón	1
20697	24	Cornice		1655	28	38	Ledge	1
20697	24	Correnti del soffitto					Corrente	1
20799	28	Dachverbindungsleiste Dakverbindingsstrip Plinthe de raccordement de toit Listón de unión del techo Roof joint ledge Correnti di collegamento del tetto		1920	3,5	20	Leiste Lat Plinthe Listón Ledge Corrente	3
26101	29	Kopfstütze Premium Hoofdsteun Premium Appui-tête Premium Reposacabezas Premium Headrest Premium Supportoi testata Premium						3
19130	O5	Abluftregelbrett Plankje regeling luchtafvoer Planche de régulation de l'air Tablero de regulación de aire Exhaust air board Tavoletta di regolazione della ventila- zione		300	95	18	Glatkant Gladde kant Angle lisse Borde listo smooth-edged Bordo levigato	1
26480	O9	Kabelleiste Afdeklat bedrading Plinthe à câbles Listón de cables Cable cover strip Listello per i cavi		1823	26	110	Brett Plank Planche Tablero Board Tavoletta	1
52063	L1	Liege Ligbank Banc		2243	550	90	Vormontiert Voorgemonteerd Prémonté	3
52065	L2	Banco Bench Panca		1177	500	90	Premontado pre-assembled Premontato	1



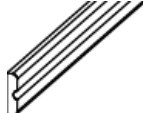



Saunagrundkörper: Saunacabine: Corps de base sauna: Cuerpo base de sauna: Sauna cabin: Cabina della sauna:				Maße in mm Afmetingen in mm Dimensions en mm Dimensiones en mm Dimensions in mm Misure in mm			Modell: Model: Modèle: Modelo: Model: Modello:	86432
Pos. Pos. Pos. Pos. Pos.	Nr. Nr. N° N° No. N°	Bezeichnung Benaming Désignation Denominación Description Descrizione	Bild Afbeelding Illustration Dibujo Illustration Immagine	Länge Lengte Long- ueur Longi- tud Length Lungh.	Breite Breedte Largeur Ancho Width Largh.	Stärke Dikte Épais- seur Espesor Thick- ness Spess.	Material Materiaal Matériau Material Material Materiale	Stück Aantal Pièce Ctdad Num- ber Q.tà
26119	L11	Liegenblende Afwerklát ligbank		2243	22	90		1
26156	L10	Rebord banc Cubierta del banco		1177	22	90		1
26155	L12	Bench face Tavola di chiusura della panca		1745	22	90		1
26146	L5	Liegenhalterung Ligbankhouder Support banc		1120	28	38	Leiste Lat Plinthe Listón Ledge Corrente	4
21788	L6	Soporte del banco Support for bench Supporto della panca		575	28	38		1
20928	L9	Stoppklotz Stopblokje Taquet de blocage Taco de bloqueo Stop block Blocchetto di arresto		60	28	38	Leiste Lat Plinthe Listón Ledge Corrente	2
40607	L7	Liegenstütze		813	72	95	Vormontiert Voorgemonteerd Prémonté Premontado pre-assembled Premontato	1
26114		Türgriff Set Karibu Deurgreep set Karibu Set poignée de porte Karibu Maneta de la puerta juego Karibu Door handle set Karibu Set Karibu di maniglie per porte						1
48522	A1	Brett Aufrecht (Goldkante) Plank verticaal (afgeronde rand) Planche verticale (bord doré) Tablero vertical (borde dorado)		2040	17	95	Brett Plank Planche Tablero Board Tavoletta	2
48523	A2	Board upright (gold edge) Tavola verticale (spigolo arrotondato)		2040	17	78		4
26216	B3	Kranzbrett Front Kranslijst voorzijde Planche de couronne façade Tablero de la corona delantera Faceplate front Marcapiano anteriore		1908	26	140	Brett Plank Planche Tablero Board Tavoletta	1
26215	B2	Kranzbrett Eingang Kranslijst ingang Planche de couronne entrée Tablero de la corona entrada Faceplate entrance Marcapiano ingresso		932	26	190	Brett Plank Planche Tablero Board Tavoletta	1
40578	B1	Kranzbrett Links Kranslijst links Planche de couronne gauche Tablero de la corona izquierda Faceplate left Marcapiano sinistro		1846	26	140	Brett Plank Planche Tablero Board Tavoletta	1

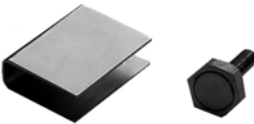
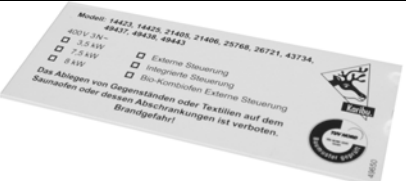





Saunagrundkörper: Saunacabine: Corps de base sauna: Cuerpo base de sauna: Sauna cabin: Cabina della sauna:				Maße in mm Afmetingen in mm Dimensions en mm Dimensiones en mm Dimensions in mm Misure in mm			Modell: Model: Modèle: Modelo: Model: Modello:	86432
Pos. Pos. Pos. Pos. Pos.	Nr. Nr. N° N° No. N°	Bezeichnung Benaming Désignation Denominación Description Descrizione	Bild Afbeelding Illustration Dibujo Illustration Immagine	Länge Lengte Long- ueur Longi- tud Length Lungh.	Breite Breedte Largeur Ancho Width Largh.	Stärke Dikte Épais- seur Espesor Thick- ness Spess.	Material Materiaal Matériau Material Material Materiale	Stück Aantal Pièce Ctdad Num- ber Q.tà
40613	B4	Kranzbrett Rechts Kranslijst rechts Planche de couronne droite Tablero de la corona derecha Faceplate right Marcapiano destro		2505	26	140	Brett Plank Planche Tablero Board Tavoletta	1
26209	C1	Kranzverbinder Verbindingsstukje kranslijst Raccord couronne		400	26	140		2
26210	C2	Elemento de unión de la corona Face joint Giunti del marcapiano		298	26	140		1
26156	D4	Kranz rechts Kranslijst rechts		1177	22	90		1
60863	D5	Couronne droite Corona derecha Face right Marcapiano destro		1325	22	90		1
60862	D1	Kranz links Kranslijst links Couronne gauche Corona izquierda Face left Marcapiano sinistro		1925	22	90		1
60858	D3	Kranz Front Kranslijst voorzijde Couronne façade Corona delantera Face front Marcapiano anteriore		2010	22	90		1
60859	D2	Kranz Tür Kranslijst deur Couronne porte Corona puerta Face door Marcapiano porta		850	22	90		1
26049		Ofenschutz Premium Kachelbeschermrekje Premium Protection poêle Premium Protección del horno Premium Oven protection Premium Protezione stufa Premium						1
14836		Kranzleuchten Halogeenlampjes Luminaire couronne Luces corona Faceplate lighting Illuminazione marcapiano						6
14016		40mm Fenster 40mm raam 40mm Fenêtre 40mm ventana 40mm window Finestra da 40mm						2







Saunagrundkörper: Saunacabine: Corps de base sauna: Cuerpo base de sauna: Sauna cabin: Cabina della sauna:				Maße in mm Afmetingen in mm Dimensions en mm Dimensiones en mm Dimensions in mm Misure in mm			Modell: Model: Modèle: Modelo: Model: Modello:	86432
Pos. Pos. Pos. Pos. Pos.	Nr. Nr. N° N° No. N°	Bezeichnung Benaming Désignation Denominación Description Descrizione	Bild Afbeelding Illustration Dibujo Illustration Immagine	Länge Lengte Longueur Longitud Length Lungh.	Breite Breedte Largeur Ancho Width Largh.	Stärke Dikte Épaisseur Espesor Thickness Spess.	Material Materiaal Matériau Material Material Materiale	Stück Aantal Pièce Ctdad Number Q.tà
50121		Bankblende Gr. 1 Afwerklát ligbank set 1 Rebord de banc Set 1 Cubierta del banco juego 1 Bench covering set 1 Set tavole della panca 1					Extra Anleitung 50121 Extra handleiding 50121 Notice séparée 50121 Instrucciones separadas 50121 separate instructions 50121 Istruzioni a parte 50121	1
50425		Rückenlehne Set 1 Rugleuning set 1 Dossier Set 1 Respaldo juego 1 Backrest set 1 Set schienale 1					Extra Anleitung 50425 Extra handleiding 50425 Notice séparée 50425 Instrucciones separadas 50425 separate instructions 50425 Istruzioni a parte 50425	1
40616		Regal Premium 3 Rekje Premium 3 Étagère Premium 3 Estantería Premium 3 Shelf Premium 3 Mensola Premium 3					Extra Anleitung 86570 Extra handleiding 86570 Notice séparée 86570 Instrucciones separadas 86570 separate instructions 86570 Istruzioni a parte 86570	1







Art.Nr. Art.nr. Article n° N° artículo Art. no. Art.N°	Artikel Artikel Article Artículo Article Articolo	Größe Maat Taille Tamaño Size Dimens.				Stück Aantal Pièce Ctdad. Number Q.tà
26115	Spezialschraube außen Speciale schroef buitenzijde Vis spéciale extérieur Tornillo especial exterior Special screw outer Vite speciale esterna	4	35		Torx Torx Torx Torx Torx Torx	50
26116	Abdeckkappen Afdekkapjes Capuchons Tapas Cover caps Tappi					50
3687	Spax	4	35			60
21925	Spax-schroeven	4	40			20
3688	Vis Spax	4	50			100
3689	Tornillo Spax	4	70			25
14014	Spax joint Viti a croce	6	60			25
14025	Dichtband Afdichttape Bande d'isolation Cinta aislante Sealing tape Nastro sigillante					10m
14266	Türspezialschraube Speciale deurschroef Vis spéciale porte Tornillo especial para puertas Special door screw Viti speciali per la porta					6

Art.Nr. Art.nr. Article n° N° artículo Art. no. Art.N°	Artikel Artikel Article Artículo Article Articolo	Größe Maat Taille Tamaño Size Dimens.			Stück Aantal Pièce Ctdad. Number Q.tà
14018	Gewindeschraube mit Scheibe und Mutter Tapschroef met sluitring en moer Vis fileté avec rondelle et boulon Tornillo fileteador con arandela y tuerca Threaded screw with washer and nut Vite filettata con rondella e bullone	8	70	nur bei Modellen mit 3 Liegen alleen bij modellen met 3 ligbanken seulement pour modèles à 3 bancs Sólo en modelos con 3 bancos only for models with three benches solo per i modelli con 3 panche	3
20803	Winkel Hoekijzer Équerre Escuadra Bracket Angolare				2
22047	Türmagnetset Deurmagneetset Set d'aimants pour porte Juego de imanes para la puerta Door magnet set Set serratura magnetica della porta				2
49869	TÜV-Schild für Saunaofen inkl. 4 Schrauben				1

					
Bei späteren Beanstandungen bitte diese Packliste einsenden.	Bij eventuele reclamaties deze paklijst opsturen a.u.b.	Veillez joindre cette liste de pièces lors de toute réclamation ultérieure.	Para posibles reclamaciones, enviar esta lista de materiales.	In case of later complaints, send in this packing list.	In caso di reclami si prega di allegare questa distinta.
Werkzeugbedarf: Bohrmaschine oder Akku-Schrauber, Kreuz Schraubendreher, 3,5 5mm und 8mm Bohrer, Wasserwaage, Hammer, Feinsäge, Zollstock, evtl. Holzleim, Senkstift, 10er und 13er Maulschlüssel.	Benodigd gereedschap: Boormachine of accuschroefmachine, kruiskop-schroevendraaier, boortjes van 3,5, 5 en 8 mm., waterpas, hamer, kapzaag, duimstok, evtl. houtlijm, drevvel, open ringsleutel 10 en 13.	Outillage nécessaire : Perceuse ou visseuse électrique, tournevis cruciforme, mèches de 3,5 5mm et 8mm, niveau, marteau, scie fine, mètre pliant, éventuellement colle à bois, cheville, clé de 10 et de 13.	Herramientas necesarias: Taladradora o atornilladora con acumulador, destornillador para tornillos de cabeza ranurada en cruz, brocas de 3,5, 5 y 8 mm, nivel de albañil, martillo, sierra de dentado fino, metro plegable, posiblemente cola para madera, espiga de cabeza cónica, llave de boca de 10 y 13	Required tools: electric drill or accu screwdriver, cross-tip screwdriver, 3,5mm, 5mm and 8mm drills, spirit gauge, hammer, mitre saw, ood glue, sunken pegmetre stick, if possible w, no. 10 and no. 13 combination spanners.	Attrezzi necessari: Trapano o cacciavite elettrico, cacciavite a croce, punte da trapano da 3,5, 5 e 8 mm, livella a bolla, martello, sega, metro, eventualmente colla per legno, punzone, chiavi per viti esagonali da 10 e da 13 mm.

					
Bei eventuellen Beanstandungen bitte diese Packliste einsenden.	Bij eventuele reclamaties deze paklijst opsturen a.u.b.	Veillez envoyer cette liste de colis lors de toute réclamation.	Para posibles reclamaciones, enviar esta lista de materiales.	In case of later complaints, send in this packing list.	In caso di eventuali reclami si prega di allegare questa distinta.
Werkzeugbedarf: Bohrmaschine oder Akku-Schrauber, Kreuz-Schraubendreher, 3,5 – 5,5 und 8 mm Bohrer, Wasserwaage, Hammer, Feinsäge, Zollstock, 13er	Benodigd gereedschap: Boormachine of accuschroefmachine, kruiskopschroeven draaier, boortjes van 3,5, 5 en 8 mm., waterpas,	Outillage nécessaire : Perceuse ou tournevis électrique, tournevis cruciforme, mèches de 3,5 – 5,5 et 8 mm, niveau,	Herramientas necesarias: Taladradora o atornilladora con acumulador, destornillador para tornillos de cabeza ranurada en cruz, brocas de 3,5 – 5,5	Required tools: electric drill or accu screwdriver, cross-tip screwdriver, 3,5mm - 5,5mm and 8mm drills, spirit gauge, hammer, mitre saw, metre stick, no. 13	Attrezzi necessari: Trapano o cacciavite elettrico, cacciavite a croce, punte da trapano da 3,5 - 5,5 e 8 mm, livella a bolla, martello, sega, metro, chiave per viti esagonali

					
Maulschlüssel, torx Schraubendreher, Senkstift.	hamer, kapzaag, duimstok, open ringsleutel 13, torx-sleutel, drevel.	marteau, scie fine, mètre pliant, clé de 13, tournevis Torx, cheville.	y 8mm, nivel de albañil, martillo, sierra de dentado fino, metro plegable, llave de boca de 13, destornillador para Torx, perno.	combination spanne, Torx screwdriver, sunken peg.	da 13, cacciavite per viti torx e punzone.

					
Was wird mit welchem Verbindungsmittel miteinander verbunden? Bitte beachten Sie, das Sie sämtliche Schraubverbindungen vorbohren müssen, um zu verhindern das sich das eingesetzte Holz spaltet.	Wat wordt met welk verbindingsmiddel met elkaar verbonden? Let op dat u alle schroefverbindingen moet voorboren om te voorkomen dat het gebruikte hout splijt.	Qu'est-ce qui est joint ensemble, et avec quels moyens de fixation ? Veuillez observer que vous devez percer auparavant l'ensemble des fixations à vis afin d'éviter que le bois utilisé ne se fende.	¿Qué se une a qué y con qué medio de unión? Tenga en cuenta que todas las uniones atornilladas se han de pretaladrar para evitar que se astille la madera utilizada.	What is joined to what with which connecting devices? Please note that it is necessary to pre-drill all screw connections in order to prevent splitting of the wood used.	Quali parti vanno collegate tra loro e con quali mezzi? Si raccomanda di preforare sempre prima di avvitare, in modo da evitare che il legno si rompa.

Elemente Elementen Éléments Elementos Element Elementi	Verbindungsmittel Verbindingsmiddel Moyen de fixation Medio de unión Fixture Collegamento		Stück Aantal Pièce Ctdad. Number Q.tà	∅ Voorbooring Voorgeboord Percement pretaladro pre-drilling diameter foro
Wandelemente untereinander Wandelementen onderling Éléments muraux les uns sous les autres Elementos de la pared entre sí Wall elements under each other Elementi delle pareti tra loro	4 x 50	pro Saunaecke (Ober und Unterteil jeweils 3Stk. (oben mittig, unten) Per hoek van de sauna (boven- en onderdeel telkens 3 (boven midden, onder) Par coin du sauna (pièce haut et bas) respectivement 3 pces (haut, milieu, bas) Para cada esquina de la sauna (parte superior e inferior) respectivamente 3 unidades (arriba, centro, abajo) per sauna corner (upper and lower part, three each (top, centre, bottom) per ogni angolo della sauna (3 pezzi sopra e 3 sotto) (sopra, al centro, sotto)	6	3,5
rundes Fenster und Tür mit Wand Rond raam en deur met wand Fenêtre ronde et porte avec mur Ventana redonda y puerta con la pared Round window and door with wall Finestra e porta rotonde con la parete	4 x 35	pro Seite per zijde par côté por lado per side per ciascun lato	5	3,5
Tür mit Elementen Deur met elementen Porte avec éléments Puerta con elementos Door with elements Porta con gli elementi	Tür-Spezialschraube	pro Seite per zijde par côté por lado per side per ciascun lato	3	
Deckenleisten mit Elementen Afdeklatten plafond met elementen Plinthes de plafond avec éléments Listones del techo con elementos Cornices with elements Listelli del soffitto con gli elementi	4 x 50	pro Seite per zijde par côté por lado per side per ciascun lato	5	3,5

Elemente Elementen Eléments Elementos Element Elementi	Verbindungsmittel Verbindingsmiddel Moyen de fixation Medio de unión Fixture Collegamento		Stück Aantal Pièce Ctdad. Number Q.tà	∅ Voorboord Percement pretaladro pre-drilling diameter foro
Dach mit Deckenleisten Dak met afdeklatten plafond Toit avec plinthes de plafond Tejado con listones del techo Roof with cornices Tetto con i listelli del soffitto	4 x 50	pro Seite per zijde par côté por lado per side per ciascun lato	3	3,5
Liegenhalterungen an Wand Ligbankhouders aan wand Supports banc sur mur Soportes del banco a la pared Supports for benches on wall Supporti delle panche con la parete	6 x 60	pro Stk per stuk par pce por pieza per piece per pezzo	3	5,5
Stoppklotz an Liegenhalterung Stopblokje aan ligbankhouder Taquet de blocage sur support banc Bloque de retención al soporte del banco Stop block on support for bench Blocchetto di arresto con i supporti delle panche	6 x 60	pro Stk per stuk par pce por pieza per piece per pezzo	2	5,5
Eckliege an lange Liege	8x70 Gewindeschraube mit Scheiben und Muttern und Winkel 8x70 Tapschroef met sluitringen en moeren en hoekijzer Vis fileté 8x70 avec rondelles et boulons avec équerre Tornillo de rosca 8x70 con arandelas y tuercas y ángulos Threaded screw 8 x 70 with washers, nuts and bracket Viti filettate 8x70 con rondelle e bulloni ed angolare			3 2
Winkel an Eckliege (nur bei Eckbank)	4 x 30	pro Winkel per hoekijzer par équerre por escuadra per bracket Per ogni angolare	8	2,5
Kabelkanalabdeckung mit Wandelement Afdeklat bedrading met wandelement Canal de couverture des câbles avec élément mural Cubierta del canal de cables con el elemento de la pared Cable cover strip with wall element Rivestimento scanalato dei cavi con l'elemento della parete	4 x 35	nach Bedarf zoveel als nodig selon le besoin según necesidad as required se necessario		3,5
Abluftregelbrett an Wand Plankje regeling luchtafvoer aan wand Planche de régulation de l'air sur mur Tablero de regulación de aire en la pared Exhaust air control board on wall Tavoletta di regolazione della ventilazione con la parete	4 x 50		1	3,5
Leistenset an Sauna Lattenset aan sauna Set de plinthes sur sauna Juego de listones en la sauna Ledge set on sauna Set di listelli con la cabina	Spezialschrauben mit Abdeckkappe			
lange Liegen untereinander	4 x 50	insgesamt	4	3,5
lange Liege an Wand	4 x 50	insgesamt	4	3,5
Liegenstütze an lange Liegen	4 x 50	pro Seite per zijde par côté por lado per side per ciascun lato	2	3,5

Elemente Elementen Eléments Elementos Element Elementi	Verbindungsmittel Verbindingsmiddel Moyen de fixation Medio de unión Fixture Collegamento		Stück Aantal Pièce Ctdad. Number Q.tà	∅ Vorbohrung Voorgeboord Percement pretaladro pre-drilling diameter foro
Kranzverbinder an Kranzbretter Verbindingsstukjes kranlijst aan kranlijsten Raccord couronne sur planches de couronne Elemento de unión de la corona al tablero de la corona Face joint on faceplates Collegamenti del marcapiano con i listelli del marcapiano	4 x 40	pro Stk per stuk par pce por pieza per piece per pezzo	6	3,5

					
<p>Allgemein: Bitte beachten Sie, das Sie sämtliche Schraubverbindungen vorbohren müssen, um zu verhindern das sich das eingesetzte Holz spaltet. Welches Verbindungsmittel wo eingesetzt wird entnehmen Sie der Tabelle: „Was wird mit welchem Verbindungsmittel miteinander verbunden?“. Dort finden Sie auch die Durchmesser der zu setzenden Vorbohrungen. Die Seitenwände sollten mit Abstand zur Wand montiert werden, damit man die Eckverbindung von außen verschrauben kann. Die Seitenwände müssen mit der Wasserwaage ausgerichtet werden. Bitte bauen Sie die Sauna im rechten Winkel auf. Tipp: Wenn das Dach nicht passt, z.B.: schräg zu den Wänden zu verlaufen scheint, oder zu kurz oder zu lang ist, überprüfen Sie bitte dann an der Übersicht, ob Sie die Eckverbindung richtig gesetzt haben. Ein weiteres Indiz auf falsch gesetzte Ecke ist, wenn die Liegen zu kurz bzw. zu lang erscheinen.</p> <p><u>Die Oberkante der Wände bildet die zugeschnittene Seite.</u></p> <p>Reihenfolge Aufbau: Als erstes sollten Sie die Türscheibe nach anliegender Anleitung mit dem Türrahmen verbinden. Dann folgt die Montage des Saunagrundkörpers mit Leistenset sowie Türgriff. Bauen Sie danach die</p>	<p>Algemeen: Let er op, dat u alle schroefverbindingen moet voorboren om te voorkomen dat het gebruikte hout splijt. Welk verbindingmiddel waar wordt toegepast, vindt u in de tabel: „Wat wordt met welk verbindingmiddel met elkaar verbonden?“. Daar vindt u ook de diameters van de voor te boren gaten.</p> <p>De zijwanden moeten op enige afstand van de muur worden gemonteerd zodat de hoekverbinding van buitenaf kan worden geschroefd. De zijwanden moeten m.b.v. een waterpas worden afgesteld. Zorg ervoor dat de sauna haaks wordt opgebouwd.</p> <p>Tip: Als het dak niet past, bijv.: schuin t.o.v. de wanden lijkt te lopen, of te kort of te lang is, controleer dan a.h.v. het overzicht of u de hoekverbinding correct hebt gemaakt. Een andere indicatie voor een verkeerd gemaakte hoek is als de ligbanken te kort of te lang lijken te zijn.</p> <p><u>De bovenkant van de wanden vormt de op maat gemaakte kant.</u></p> <p>Volgorde opbouw: Als eerste moet de glazen deur volgens de bijgaande handleiding aan het deurkozijn worden bevestigd. Daarna volgt de montage van de saunacabine met de afdeklatten en de handgreep van de deur. Monteer daarna de onderdelen van het interieur zoals het kachelbeschermrekje, de</p>	<p>Généralités : Veuillez observer que vous devez percer auparavant l'ensemble des fixations à vis afin d'éviter que le bois utilisé ne se fende. Pour savoir quel moyen de fixation est utilisé à quel endroit, veuillez consulter le tableau « Qu'est-ce qui est joint ensemble, et avec quels moyens de fixation ? ». Vous y trouverez aussi le diamètre des percements à effectuer.</p> <p>Les murs latéraux devraient être montés avec une certaine distance par rapport au mur pour pouvoir visser le raccord d'angle de l'extérieur. Les murs latéraux doivent être dressés à l'aide d'un niveau. Veuillez construire le sauna en angle droit.</p> <p>Astuce : si le toit ne convient pas, par ex. : s'il semble être incliné par rapport aux murs, ou s'il est trop court ou trop long, veuillez alors vérifier sur l'aperçu général si vous avez correctement monté le raccord d'angle. Un autre indice montrant que l'angle est mal posé est lorsque les bancs semblent trop courts ou trop longs.</p> <p><u>Le bord supérieur des murs est le côté découpé.</u></p> <p>Ordre de montage : En premier, vous devriez joindre la vitre de porte au cadre de porte selon la notice jointe. Ensuite a lieu le montage du corps de base du sauna avec le set de plinthes et de poignée de porte. Construisez ensuite l'aménagement intérieur comme la protection du poêle,</p>	<p>Generalidades: No olvide que debe pretaladrar todas las uniones atornilladas para evitar que la madera se abra. De la tabla se desprende qué medio de unión se ha de utilizar dónde: "¿Qué se une entre sí y con qué medio de unión?": Ahí, usted encuentra también los diámetros de los pretaladros a realizar.</p> <p>Las paredes laterales deberían montarse con distancia a la pared para que se puedan atornillar las uniones de las esquinas. Las paredes laterales se han de alinear con el nivel de albañil. Construya la sauna en ángulo recto.</p> <p>Consejo: Si el techo no se adapta bien, p. ej. parece que discurre inclinadamente a las paredes, o es muy corto o muy largo, comp-ruebe en la vista general si la unión de las esquinas se ha efectuado correctamente. Otro indicio sobre esquinas mal colocadas es el hecho de que los bancos parezcan demasiado cortos o demasiado largos.</p> <p><u>El borde superior de las paredes forma un lado recortado.</u></p> <p>Secuencia de montaje: Primero una la hoja de la puerta al marco de la puerta de conformidad con las instrucciones adjuntas. A continuación sigue el montaje del cuerpo base de la sauna con el juego de listones y la manilla de la puerta. Posteriormente, monte el equipo interior como protección del</p>	<p>General: Please note that it is necessary to pre-drill all screw connections in order to prevent splitting of the wood used. The table "What is joined to what with which fixtures?" describes where which connecting devices are used. There you will also find the diameters of for the pre-drilling steps.</p> <p>The side walls should be installed at a distance from the wall, so that the corner joint can be screwed down from the outside. Align the side walls with the spirit gauge. Make certain to erect the sauna strictly vertically.</p> <p>Tip: If the roof does not fit, e.g. appears to be inclined in relation to the walls or is too long or too short, check whether you have placed the corner joint correctly. If the benches appear to be too long or too short, this is a further indication of an incorrectly placed corner.</p> <p><u>The upper edge of the walls forms the pre-cut side.</u></p> <p>Assembly procedure: Firstly, you should attach the door plate to the door frame as described in the accompanying instructions.</p> <p>Then assemble the sauna cabin with the ledge set and the door handle. This is followed by the interior equipment, such as the oven protection, benches, etc. If you install a window in your sauna, you should be aware of possible conflicts here.</p>	<p>Generalità: Si raccomanda di preforare sempre prima di avvitare, in modo da evitare che il legno si rompa. Nella tabella si può vedere quali viti ed accessori si debbano di volta in volta usare per collegare i pezzi tra loro. „Quali parti vanno collegate tra loro e con quali mezzi?“ Vengono indicati anche i diametri dei fori che si devono eseguire.</p> <p>Le pareti laterali non vanno montate troppo vicino alle pareti della stanza, in modo da poter avvitare gli angoli dall'esterno. Le pareti laterali vanno orientate con la livella a bolla. Montare la sauna a squadra.</p> <p>Consiglio: Se il tetto non combacia, ad es.: se sembra essere storto rispetto alle pareti o troppo breve o troppo lungo, controllare nello schema generale se i collegamenti degli angoli sono stati montati correttamente. Un ulteriore indizio del fatto che gli angoli sono stati montati in modo errato è che le panche diventano troppo corte o troppo lunghe.</p> <p><u>Lo spigolo superiore della parete costituisce il lato tagliato su misura.</u></p> <p>Montare seguendo le istruzioni: Per prima cosa fissare il vetro della porta agli stipiti della porta, come indicato nelle istruzioni allegate. Segue quindi il montaggio del corpo della sauna, con il set di listelli e la maniglia della porta. Quindi arredare l'interno, con</p>





















					
Inneneinrichtung wie Ofenschutz, Liegen usw.. Falls Sie ein Fenster in Ihre Sauna bauen, sollten Sie hierbei schon auf eventuelle Konflikte diesbezüglich achten.	ligbanken enz. Als u een raam in uw sauna wilt maken, dient u hiermee nu al rekening te houden.	les bancs etc. Si vous construisez une fenêtre dans votre sauna, vous devriez à cette occasion déjà veiller à d'éventuels conflits concernant ceci.	horno, banco, etc. Si desea montar una ventana en su sauna, en este momento ya debería tener en cuenta posibles conflictos.		la protezione per la stufa, le panche ecc. Se si vuole mettere una finestra si dovrebbe valutare le diverse problematiche fin da ora.
Saunagrundkörper und Leistenset: Abb.: --> Abbildung Abb.1-1 Hier finden Sie eine bemasste Draufsicht für Ihre Kontrolle beim Aufbau. Bitte beachten Sie wie Sie die Eckverbindungen der Wandelemente untereinander setzen!	Saunacabine en set afdekplaten: Afb.: --> afbeelding Afb.1-1 Hier vindt u een bovenaanzicht met afmetingen ter controle tijdens het opbouwen. Let erop, hoe u de hoekverbindingen van de wandelementen ten opzichte van elkaar plaatst a.u.b.!	Corps de base du sauna et set de plinthes : Fig. : → Figure Fig.1-1 Vous trouvez ici un aperçu métré pour votre contrôle lors du montage. Veuillez observer comment vous avez placé les raccords d'angle des éléments muraux les uns en dessous des autres !	Cuerpo de la sauna y juego de listones: Ilust.: >> Ilustración Ilustr. 1-1 Usted encuentra aquí una vista en planta para su control durante el montaje. Tenga en cuenta la forma en que coloca las uniones de las esquinas de los elementos de la pared entre sí.	Sauna cabin and ledge set: Fig.: --> Figure Fig. 1-1 This figure is a top view showing the dimensions and serves as a check during assembly. Please make certain to install the corner joints for the wall elements correctly under each other!	Corpo della sauna e set di listelli: Imm. Immagine Imm. 1-1 È illustrato uno schema con le quote per il controllo durante il montaggio. Osservare come gli elementi degli angoli vanno disposti tra gli elementi delle pareti!
Abb.2-1 Die unteren Wandelemente miteinander verschrauben. Mit je 3 Spax pro Seite und Einzelteil (oben, mittig, unten). Dabei müssen auch die Ober- und Unterteile miteinander verbunden werden.	Afb.2-1 Schroef de onderste wandelementen aan elkaar vast. Met telkens 3 spaxschroeven per zijde en afzonderlijk deel (boven, in het midden, onder). Daarbij moeten ook de boven- en onderdelen met elkaar worden verbonden.	Fig.2-1 Visser ensemble les éléments muraux du bas avec respectivement 3 vis spax par côté et par pièce (en haut, au milieu, en bas). Les pièces supérieures et inférieures doivent également être jointes ensemble.	Ilust.2-1 Atornille entre sí los elementos de la pared inferiores. Con 3 Spax por lado y pieza suelta (arriba, centro, abajo). Al mismo tiempo, las piezas superiores e inferiores también se han de unir entre sí.	Fig. 2-1 Join the lower wall elements to each other with screws, using three Spax joints per side and individual section (top, centre, bottom). The upper and lower sections must also be joined to each other.	Imm. 2-1 Collegare tra loro gli elementi inferiori delle pareti. Con 3 viti a croce per lato e per elemento (sopra, in mezzo, sotto). Anche l'elemento superiore e quello inferiore devono essere collegati tra loro.
Abb.2-2 Pos 1 geht durch	Afb.2-2 Pos. 1 loopt door	Fig.2-2 Pos. 1 continue	Ilust.2-2 Pos. 1 continúa	Fig. 2-2 Pos. 1 passes through the entire height.	Imm. 2-2 Posizione 1 continua
Abb.2-3 Die Wandoberteile aufsetzen. Beim Verschrauben der Einzelteile beachten, dass die Ober- und Unterteile miteinander verbunden werden!	Afb.2-3 Plaats de bovenste wanddelen. Let er bij het vastschroeven van de afzonderlijke delen op, dat de boven- en onderdelen met elkaar worden verbonden!	Fig.2-3 Poser les pièces murales supérieures. En vissant les différentes pièces, observer que les pièces supérieures et inférieures doivent être jointes ensemble	Ilust. 2-3 Colocar las partes superiores de la pared. Al atornillar las piezas sueltas, tengan en cuenta que las piezas superiores e inferiores estén unidas entre sí.	Fig. 2-3 Set on the upper wall sections. When joining the individual sections with the screws, make sure that the upper and lower sections are joined to each other!	Imm. 2-3 Disporre gli elementi superiori delle pareti. Nell'avvitare i singoli elementi si raccomanda di collegare anche la parte superiore con quella inferiore!
Abb.3-1 Den verschraubten Saunakörper in endgültige Position schieben. Dabei auf 10cm Abstand zwischen den Saunawänden und Wand achten.	Afb.3-1 Schuif de gemonteerde saunacabine op de definitieve plaats. Houd daarbij 10cm afstand aan tussen de wanden van de sauna en de muur. Schroef de systeemplaten langs de instap (pos. 5) met spaxschroeven aan de wandelementen vast	Fig.3-1 Pousser le corps du sauna vissé dans la position définitive. A cette occasion, respecter une distance de 10cm entre les murs du sauna et le mur. Visser les plinthes systèmes entrée pos. 5 avec des vis spax aux éléments muraux (voir aperçu fig.3-3).	Ilust. 3-1 Empujar el cuerpo de la sauna atornillado a la posición final. Al hacerlo, preste atención a la distancia de 10cm entre las paredes de la sauna y la pared. Atornillar los listones del sistema de entrada Pos. 5 con Spax a los elementos de la pared (ver vista en planta	Fig. 3-1 Push the assembled sauna cabin into its final position. Ensure a distance of 10cm between the sauna walls and the outer wall. Attach the entrance system ledges pos. 5 with Spax joints to the wall elements (see top view Fig. 3-3).	Imm. 3-1 Portare la cabina della sauna nella sua posizione definitiva. Mantenere una distanza di 10cm tra le pareti della sauna e quelle della stanza. Avvitare i listelli dell'ingresso (pos. 5) agli elementi delle pareti (vedere schema Imm. 3-3).

					
Abb.3-3).	(zie bovenaanzicht afb.3-3).		Ilust. 3-3)		
<p>Abb.3-2 Einstiegsbrett Pos 11 oben und unten einschrauben (siehe Draufsicht Abb.3-3).</p> <p>Achtung unbedingt darauf achten, dass die Elemente im rechten Winkel stehen!!!!</p>	<p>Afb.3-2 Schroef de deurdorpels pos. 6 aan de boven- en onderzijde vast (zie bovenaanzicht afb.3-3).</p> <p>Belangrijk: let er beslist op, dat de elementen haaks komen te staan !!!!</p>	<p>Fig. 3.2 Visser la planche d'entrée pos. 11 en haut et en bas (voir aperçu fig.3-3).</p> <p>Attention: Veiller impérativement à ce que les éléments soient en angle droit !!!!</p>	<p>Ilust. 3-2 Atornillar el tablero de entrada Pos. 11 arriba y abajo (ver vista en planta Ilust. 3-3).</p> <p>Atención: Cerciórese que los elementos estén en ángulo recto !!!!</p>	<p>Fig. 3-2 Screw down the entrance plank pos. 11 at the top and bottom (see top view Fig. 3-3).</p> <p>Attention: Make absolutely certain that the elements are erected strictly vertically!!!!</p>	<p>Imm. 3-2 Avvitare la tavoletta di ingresso (pos. 11) sopra e sotto (vedere schema Imm. 3-3).</p> <p>Attenzione! Fare attenzione a montare tutti gli elementi a squadra!!!!</p>
<p>Abb.4-1 Deckenleisten Pos 20 - Pos 24 einschrauben und Dichtband aufkleben. Siehe Abb.4-2 Oberkante Wand bis Oberkante Deckenleisten=52mm</p> <p>Achtung! Unbedingt die Elemente genau ausrichten, sonst gibt es beim Einbau der Tür Probleme!</p> <p>Die bereits montierte Tür einbauen und mit jeweils 3 Stk. Spezialschrauben seitlich im aufrechten Rahmen befestigen.</p> <p>TIPP! (Abb.4-3) Die Spezialschrauben müssen erst ganz eingeschraubt werden, anschließend kann durch herausdrehen die Tür ausgerichtet werden.</p>	<p>Afb.4-1 Schroef de deklatten onder het plafond (pos. 20 – pos. 24) en plak daarop het afdichttape. Zie afb. 4-2: bovenzijde wand tot bovenzijde afdeklaf plafond = 52mm.</p> <p>Let op! Stel de elementen beslist nauwkeurig af, anders ontstaan er bij het monteren van de deur problemen!</p> <p>Monteer de reeds gemonteerde deur en bevestig deze met telkens 3 speciale schroeven aan de zijkant in de verticale zijde van het kozijn.</p> <p>TIP! (Afb.4-3) De speciale schroeven moeten er eerst helemaal ingedraaid worden, vervolgens kan de deur worden afgesteld door de schroeven weer iets te verdraaien.</p>	<p>Fig. 4.1 Visser les plinthes de plafond pos. 20 – pos. 24 et coller la bande d'isolation. Voir fig. 4-2 bord supérieur mur jusqu'au bord supérieur plinthes de plafond = 52 mm</p> <p>Attention! Impérativement poser les éléments avec exactitude, sinon des problèmes apparaissent lors du montage de la porte !</p> <p>Intégrer la porte déjà montée et la fixer latéralement dans le cadre dressé avec 3 vis spéciales respectivement.</p> <p>ASTUCE ! (Fig.4-3) Les vis spéciales doivent d'abord être entièrement vissées avant qu'il soit possible de poser la porte en la tournant</p>	<p>Ilust. 4.1 Atornillar los listones del techo Pos. 20 – Pos. 24 y aplicar la cinta aislante. Ver Ilust. 4-2 borde superior de la pared hasta el borde superior de los listones del techo = 52 mm.</p> <p>Atención: Alinear imprescindiblemente los elementos de forma exacta, en otro caso tendrá problemas para montar la puerta.</p> <p>Montar la puerta ya premontada y fijarla con 3 tornillos especiales respectivamente lateralmente en el marco vertical.</p> <p>CONSEJO: (Ilust. 4-3) En primer lugar, atornillar los tornillos especiales, a continuación la puerta puede ajustarse aflojando los tornillos.</p>	<p>Fig. 4-1 Screw down the cornices pos. 20 - 24 and cover with sealing tape (see Fig. 4-2). The upper edge of the wall to the upper edge of the cornice must measure 52mm.</p> <p>Attention! Make absolutely certain to align the elements exactly. Otherwise, there will be problems with installing the door!</p> <p>Install the already assembled door and attach each hinge with three special screws to the side of the vertically standing frame.</p> <p>TIP! (Fig. 4-3) Firstly turn in the special screws completely. You can then align the door correctly by backing off the screws.</p>	<p>Imm. 4-1 Avvitare i listelli del soffitto (pos. 20 – pos. 24) ed applicare il nastro sigillante. Vedere l'imm. 4-2: distanza spigolo parete – listello del soffitto = 52 mm.</p> <p>Attenzione! Orientare gli elementi a squadra con precisione, altrimenti ci saranno dei problemi nel montaggio della porta!</p> <p>Montare la porta e fissarla lateralmente negli stipiti verticali con 3 viti speciali per ogni cerniera.</p> <p>CONSIGLIO! (Imm. 4-3) Inserire dapprima le viti speciali completamente, poi per regolare la porta le si potrà svitare.</p>
<p>Abb.4-4 Zuerst Dachplatte (Pos 8) auf Deckenleisten (Dichtband) legen, Dachverbindungsleiste (Pos 28) in Nut der Dachplatte einschieben, Dichtband einkleben.</p> <p>Bei 3 Dachplatten Pos 10 auflegen. Von unten mit Spax anschrauben.</p> <p>Anschließend, anschließend die Dachplatte schräg Pos 9</p>	<p>Afb.4-4 Leg eerst de dakplaat (pos. 8) op de deklatten van het plafond (afdichttape), schuif de dakverbindingsstrip (pos. 28) in de groef van de dakplaat, breng afdichttape aan.</p> <p>Bij 3 dakplaten pos. 10 opleggen. Van onderaf met spax-schroeven vastzetten.</p> <p>Vervolgens de afgeschuinde dakplaat pos. 9 opleggen en</p>	<p>Fig.4-4 D'abord poser le panneau de toit (pos. 8) sur les plinthes de plafond (bande d'isolation), pousser la plinthe de raccordement du toit (pos. 28) dans la rainure du panneau de toit, coller la bande d'isolation. Sur 3 panneaux de toit, mettre la pos. 10. Visser par le bas avec des vis spax. Ensuite, poser le panneau de toit incliné pos. 9 et visser par le</p>	<p>Ilust. 4-4 En primer lugar, colocar el tablero del techo (Pos 8) sobre los listones del techo (cinta aislante), introducir el listón de unión del techo (Pos. 28) en la ranura del tablero del techo, pegar con cinta aislante.</p> <p>Colocar en 3 tableros del techo según Pos. 10. Atornillar desde abajo con Spax. A continuación, colocar</p>	<p>Fig. 4-4 Firstly lay the roof plate (pos. 8) onto the roof ledges (sealing tape). Then slide the roof joint ledge (pos. 28) into the groove of the roof plate and fix with sealing tape. In the case of three roof plates, lay pos. 10. Attach from below with Spax joints.</p> <p>Finally, lay on the inclined roof plate pos. 9 and screw down from below.</p>	<p>Imm. 4-4 Dapprima posare le tavole del tetto (pos. 8) sui listelli del soffitto (nastro sigillante), quindi inserire i listelli di collegamento del tetto (pos. 28) nella scanalatura delle tavole del tetto ed incollare il nastro sigillante.</p> <p>Come terza tavola posare la tavola di cui in pos. 10. Avvitare le tavole da sotto con le viti a croce.</p>

					
auflegen und von unten anschrauben.	van onderaf vastschroeven.	bas.	el tablero del techo inclinado Pos. 9 y atornillarlo por debajo.		Quindi posare la tavola del tetto trasversale (pos 9) ed avvitare da sotto.
Abb. 5-1 – 5-4 Aufrechte Bretter an den Ecken der Sauna befestigen. Achtung! Auf die Breite des Premiumregales achten! Die Kranzbretter mit den Kranzverbindern verbinden und auf die Saunawände schrauben.	Afb. 5-1 – 5-4 Bevestig de verticale planken op de hoeken van de sauna. Let op! Let op de breedte van het Premiumrekje! De kranstijsten met de verbindingstukjes met elkaar verbinden en op de wanden van de sauna schroeven.	Fig.5-1 – 5-4 Fixer les planches verticales sur les coins du sauna. Attention ! Veiller à la largeur de l'étagère Premium ! Joindre les planches de couronne avec les raccords de couronne et les visser sur les murs du sauna.	Ilust. 5-1 – 5-4 Fijar los tableros verticales en las esquinas de la sauna. ¡Cuidado! Prestar atención al ancho de la estantería Premium. Unir los tableros de la corona con los elementos de unión de la misma y atornillarlos a las paredes de la sauna.	Fig. 5-1 – 5-4 Attach the vertical boards to the corners of the sauna. Attention! Make certain that the width of the Premium shelf is correct! Join the cornice boards to the cornice joint and screw down to the sauna walls.	Imm. 5-1 -5-4 Fissare le assi verticali agli angoli della sauna. Attenzione! Tener conto della larghezza della mensola Premium! Collegare le assi del marcapiano per mezzo degli appositi giunti ed avvitarle alle pareti della sauna.
Abb. 6-1 Den Kranz montieren	Afb. 6-1 Monteer de kranstijst	Fig.6-1 Monter la couronne	Ilust. 6-1 Montar la corona	Fig. 6-1 Install the face.	Imm. 6-1 Montare il marcapiano.
Abb. 6-2 Die äußeren Schrauben mit Abdeckkappen versehen.	Afb. 6-2 Voorzie de schroeven aan de buitenzijde van afdekkapjes.	Fig.6-2 Couvrir les vis extérieures avec les capuchons.	Ilust. 6-2 Tapar con las tapas correspondientes los tornillos exteriores.	Fig. 6-2 Cover over the outer screws with cover caps.	Imm. 6-2 Mettere i tappi alle viti esterne.
Die Inneneinrichtung: Liegen und Liegenhalterung					
L1 Liegenhalterungen montieren Bei der Liegenhalterung der Querliege die kürzeste Liegenhalterung verwenden. Vertikale Lage / Höhe:					
Die in der Zeichnung angegebenen Maße (Fußboden bis Unterkante Liegenhalterung angegeben) einhalten. Bei den oberen Liegenhalterungen an der Liegenstütze orientieren. Die zurückgesetzten mittleren Bretter der Liegenstütze müssen die selbe Höhe wie die oberen Liegenhalterungen haben.					
L2 Liegenhalterungen mit der Wand verschrauben. Lage der Schrauben und des Stopklotzes.					
L3-5 Montage der Querliege: Die Details sind Ansichten der Liegen von unten!					
L4 Die Befestigung ist leichter, wenn die Liegeflächen während der Montage herausge-					

					
nommen werden aus den Liegen wie hier dargestellt.					
L5 In den Rahmen der Querliege werden Winkel mit Spax festgeschraubt. Danach durch diese Winkel mit den Schlüsselschrauben die Bänke über Eck miteinander verbinden. Die 3. Schlüsselschraube setzen Sie mittig. Die Löcher für die Schlüsselschrauben müssen Seiten liegen auflegen.					
L7 Mittig unter die beiden oberen Liegen wird die Liegenstütze gestellt und von vorne und hinten mit den Liegen verschraubt. Die hintere Liege wird an der Wand angeschraubt. Die vordere Liege danach an die hintere Liege anschrauben.					
L8 Schrauben Sie die Bankblenden an die Liegen an. Die Schrauben von der Liegeninnenseite aus schrauben.					
Ofenschutz und Abluftregelung Abb.:O1 Ofenschutz montieren.	Kachelbeschermrekje en regeling luchtafvoer Afb.:O1 Montage kachelbeschermrekje.	Protection poêle et régulation de l'évacuation d'air Fig. :O1 Monter la protection de poêle.	Protección del horno y tabla de regulación del aire de salida Ilust.:O1 Montar la protección del horno.	Oven protection and exhaust air control Fig. O1 Install the oven protection.	Protezione della stufa e regolazione dell'areazione Imm.: O1 Montare la protezione della stufa.
Abb.:O2 Bringen Sie die Ofenschutzstützen an den Ofenschutz an. Die angegebenen Maße gegebenenfalls an den Ofen anpassen. Ofenschutz möglichst mittig vor das Wandelement mit der Zuluft (Front) stellen. Schrauben Sie es an diese Front an. (Beide Bretter die an der Wand sind anschrauben; X ... Lage Verschraubung) Ausnahme: Produktnummer: 85420 dort kommen die	Afb.: O2 Monteer de pootjes aan het kachelbeschermrekje. Pas de aangegeven maten evt. aan de kachel aan. Zet het kachelbeschermrekje zoveel mogelijk midden vóór het wandelement met de luchttoevoer (voorzijde). Schroef het vast aan dit voorwandeel. (Beide plankjes aan de kant van de wand vastschroeven; X ... plaats schroeven). Uitzondering: productnummer: 85420, daar komen de	Fig. : O2 Posez les supports de protection de poêle sur la protection de poêle. Ajuster le cas échéant les dimensions indiquées au poêle. Placer la protection du poêle le plus possible au milieu devant l'élément mural avec l'arrivée d'air (façade). Visser-la sur cette façade. (visser les deux planches du mur; X ... position de vissage). Exception : N° de produit 85420, sur celui-ci les vis sont placées sur le côté	Ilust.:O2 Coloque los apoyos de protección horno en la protección del horno. Dado el caso, adaptar la medida indicada al horno. Colocar la protección del horno lo más centradamente posible delante del elemento de la pared con la entrada del aire (delantero). Atorníllelo a este delantero. (Ambas tablas están atornilladas a la de la pared; X ... posición atornillada) Excepción: número de	Fig. O2 Bring the oven protection support up to the oven protection. Adapt the size the the oven if necessary. Place the oven protection as well centred as possible in front of the wall element with the air inlet (front) and screw down to this front (attach both boards on the wall; X ... position of screw attachment) Exception: product number: 85420 - here the screws are attached from the narrow side.	Imm.: O2 Fissare i supporti delle protezioni della stufa alle protezioni della stufa. Eventualmente si dovrà adattare alla stufa le dimensioni delle protezioni. Disporre la protezione della stufa il più centralmente possibile rispetto all'elemento della parete con la presa d'aria (frontale). Avvitarla a questa parete frontale. (Avvitarle entrambe le assi alla parete ; X ... Posizione viti) Eccezione: Numero prodotto:

					
<p>Schrauben in die Schmale Seite.</p> <p>Kabelleiste: Sie wird aufrecht zwischen Ofenschutz und Saunadecke mit Nägeln montiert. Wenn Sie die Elektrokabel in der Sauna vom Ofen zum Steuergerät und dann zum Dach verlegen, können Sie mit der Kabelleiste diese Kabel abdecken. Die Leiste hat verschiedene Fräsungen, damit diese für jede Ofenvariante angewendet werden kann. Verwenden Sie die Leiste so wie Sie diese benötigen.</p>	<p>schroeven in de smalle kant.</p> <p>Afdeklát bedrading: Deze wordt verticaal tussen het kachelbeschermrekje en het plafond van de sauna met spijkers gemonteerd. Als u de snoeren in de sauna van de kachel naar de regelaar en vervolgens naar het dak legt, kunt u achter deze afdeklát de bedrading wegwerken. In de lat zijn verschillende sleuven gefreesd, zodat deze voor elke kachelvariant kan worden gebruikt. Gebruik de lat al naargelang de gekochte kachel.</p>	<p>étroit.</p> <p>Plinthe à câbles : Elle est fixée debout entre la protection du poêle et le plafond du sauna avec des clous. Si vous posez les câbles électriques, dans le sauna, allant du poêle vers l'appareil de commande et ensuite vers le toit, vous pouvez recouvrir ces câbles avec la plinthe à câbles. Cette plinthe a plusieurs fraisages afin de pouvoir être utilisée pour chaque variante de poêle. Utilisez la plinthe comme vous en avez besoin.</p>	<p>producto 85420. Aquí se ponen los tornillos en la parte delgada.</p> <p>Listón para cables: Éste se coloca verticalmente entre la protección del horno y el techo de la sauna y se fija con clavos. Si usted coloca el cable eléctrico en la sauna desde el horno hasta el aparato de mando y después hasta el techo, lo puede cubrir con el listón para cables. El listón tiene diferentes fresados para que pueda utilizarse en todas las variantes de horno. Utilice el listón tal y como usted lo necesita</p>	<p>Cable cover strip: Install the cable cover strip vertically with nails between the oven protection and the sauna roof. If you lay the electric cable in the sauna from the oven to the control unit and then to the roof, you can cover the cable with this cover strip. The cover strip has different millings, so that it can be used with different oven models. Use the cover strip as required.</p>	<p>85420 in questo caso le viti vanno avvitate sul lato corto.</p> <p>Listello per i cavi: Va inchiodato verticalmente tra la protezione della stufa ed il soffitto della sauna. Quando nella sauna si posa il cavo elettrico che va dalla stufa al comando e quindi fino al tetto, rivestire il cavo con il listello per i cavi. Il listello ha diverse scanalature, per essere utilizzabile con i diversi modelli di stufa. Utilizzare il listello a seconda delle necessità.</p>
<p>Abb.:O3 Zeichnen Sie die Mitte des Abluftregelbrettchens an. Dies ist die Lage der Vorbohrung für die Schraube. Bohren Sie dort nun vor.</p>	<p>Afb.: O3 Teken het midden van het plankje voor de regeling van de luchtafvoer af. Hier moet het gaatje voor de schroef worden voorgeboord. Boor nu het gaatje voor.</p>	<p>Fig. : O3 Marquez le milieu de la planchette de régulation de l'air. Ceci est la position du percement pour la vis. Percez ici un trou avant de visser.</p>	<p>Ilust. O3 Marque el centro de la tablita de regulación de aire de salida. Ésta es la situación de la perforación previa para el tornillo. Haga aquí la perforación previa.</p>	<p>Fig. O3 Mark the centre of the exhaust air control board. This is the position of the pre-drilling for the screw. Then carry out pre-drilling.</p>	<p>Imm. O3 Segnare il centro della tavoletta di regolazione della ventilazione. In quel punto si dovrà forare la tavoletta per la vite. Eseguire il foro.</p>
<p>Abb.:O4 Legen Sie das Abluftregelbrett mittig über beide Abluftöffnungen der Rückwand. Schrauben Sie es nun mit 1 Spax 4 x 30 an.</p>	<p>Afb.: O4 Breng het plankje in het midden over beide luchtafvoeropeningen in de achterwand aan. Schroef het er nu met 1 spax-schroef 4x30 aan vast.</p>	<p>Fig. : O4 Posez la planchette de régulation de l'air au milieu par-dessus les deux ouvertures d'écoulement de l'air du mur arrière. Vissez-la maintenant avec 1 vis spax 4 x 30.</p>	<p>Ilust.: O4 Coloque la tabla de regulación de salida de aire en el centro sobre las aperturas de salida de aire de la pared posterior. Atornílela con 1 Spax 4x30.</p>	<p>Fig. O4 Place the exhaust air control board in the centre over the two exhaust air openings on the rear wall. Then attach, using one 4 x 30 Spax joint.</p>	<p>Imm. O4 Disporre la tavoletta di regolazione della ventilazione in mezzo alle due aperture di ventilazione della parete posteriore. Avvitarla con una vite a croce 4 x 30.</p>
<p>Abb.:O5-7 Hier ist die Funktionsweise des Brettes abgebildet. Regeln Sie damit die Abluft nach eigenen Wünschen.</p>	<p>Afb.: O5-7 Hier is de werking van het plankje afgebeeld. Regel daarmee de luchtafvoer naar eigen wens.</p>	<p>Fig. : O5-7 Ceci représente le mode de fonctionnement de la planche. Avec elle, réglez l'écoulement de l'air selon vos désirs.</p>	<p>Ilust. O5-7 Aquí está representada la forma de funcionamiento de la tabla. Con ellas, usted puede regular la salida de aire según su deseo.</p>	<p>Fig. O5-7 This figure shows the functional principle of the board. Regulate the exhaust air according to your own wishes.</p>	<p>Imm. O5-7 Viene illustrato il principio di funzionamento della tavoletta di regolazione della ventilazione. Con essa si può regolare a piacere la ventilazione.</p>



Abb.1-1



Abb.2-1

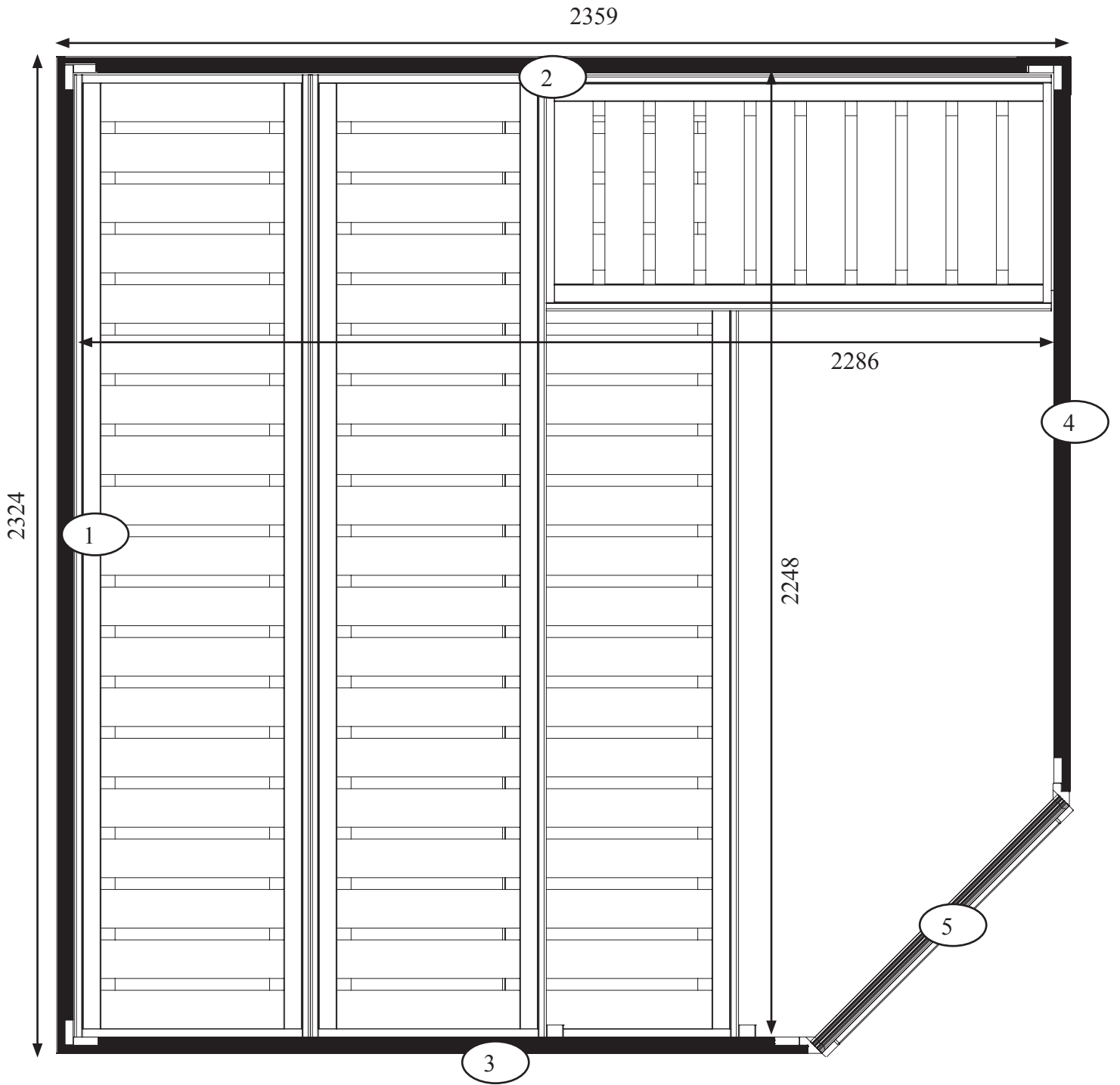

Abb.2-2

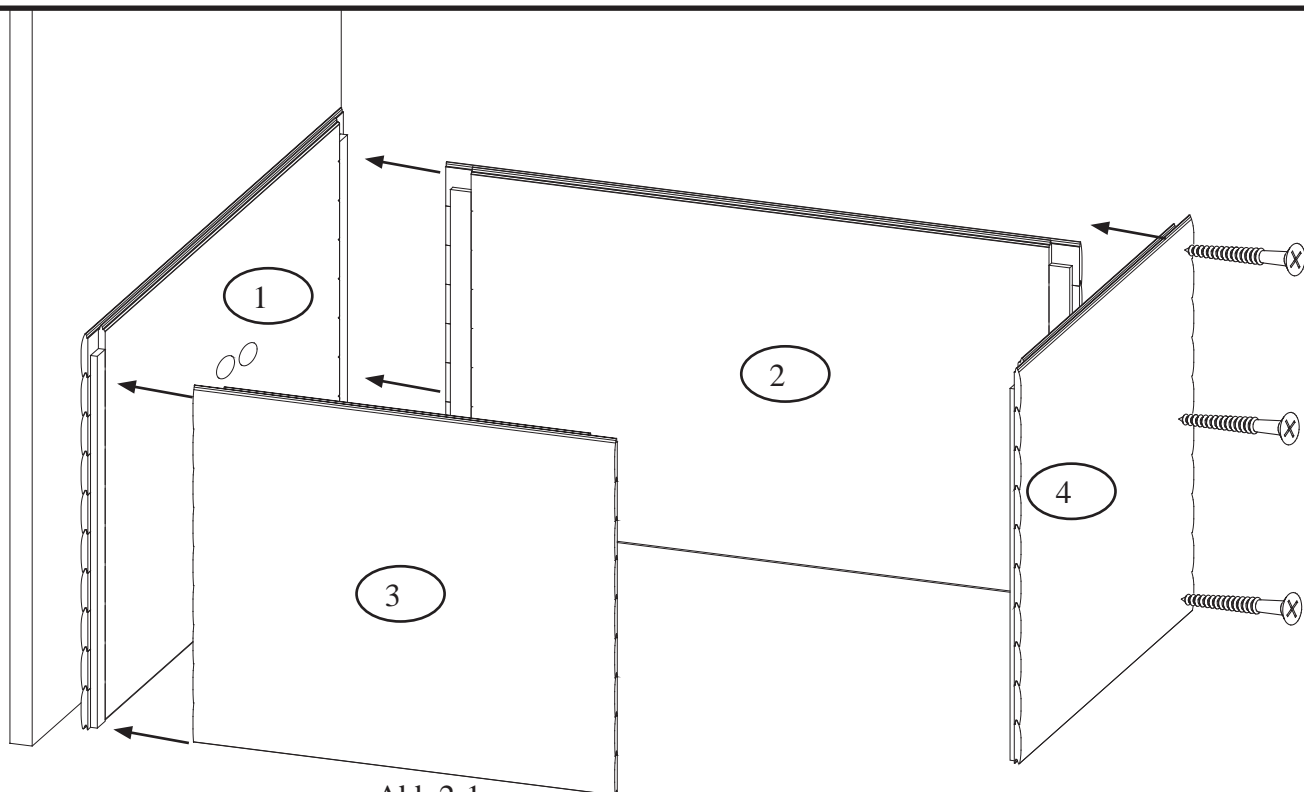

Abb.2-3

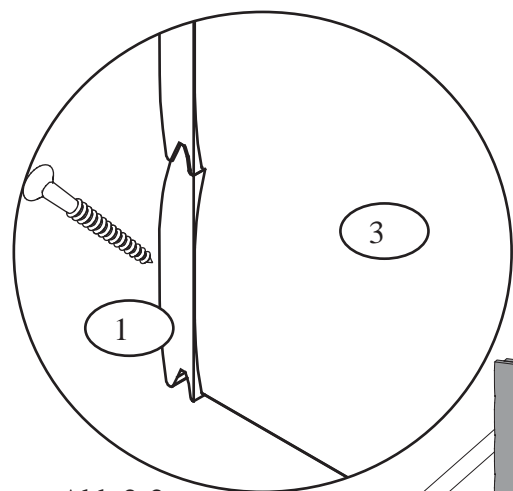

Abb.3-1

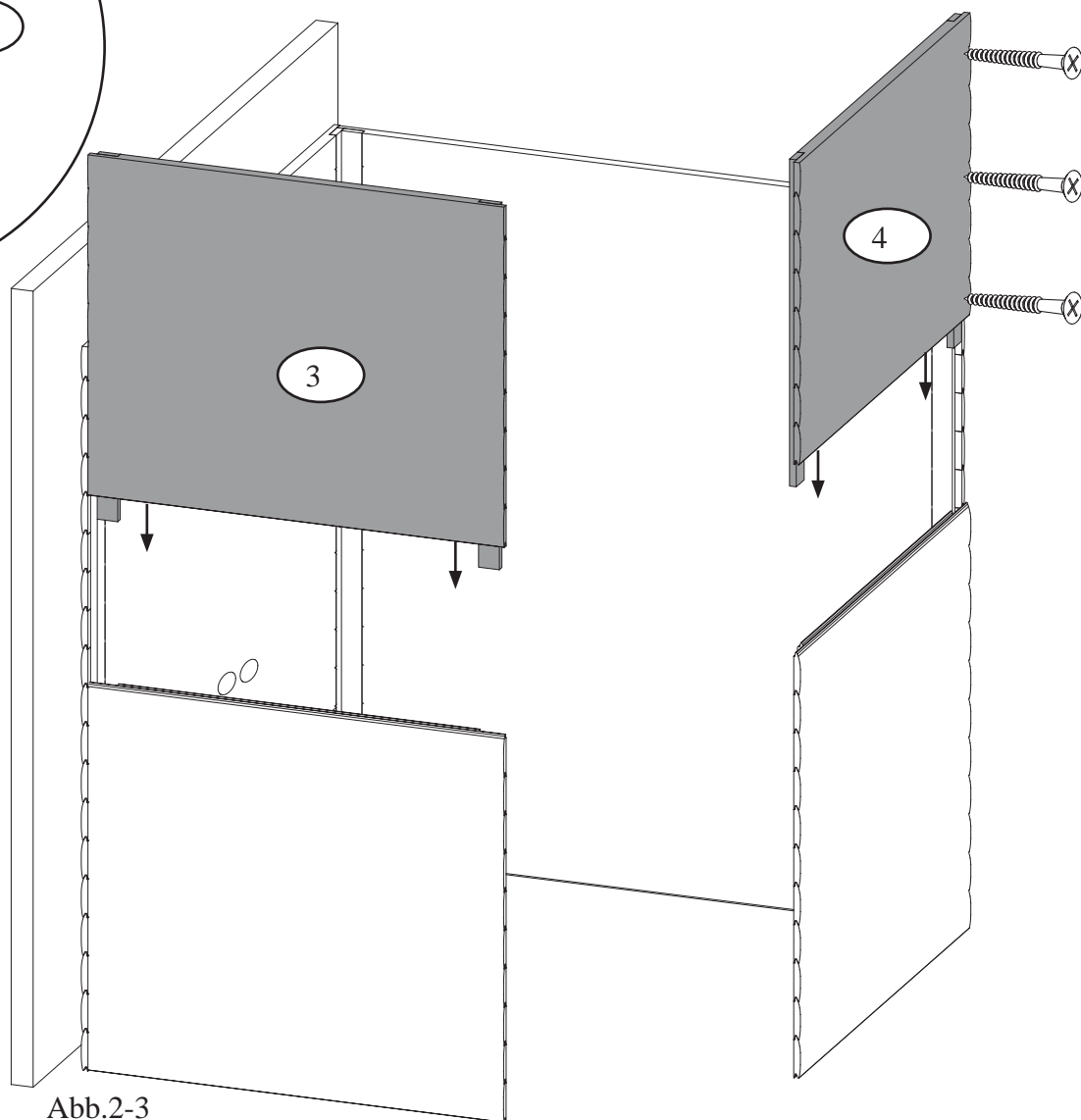

Abb.3-2

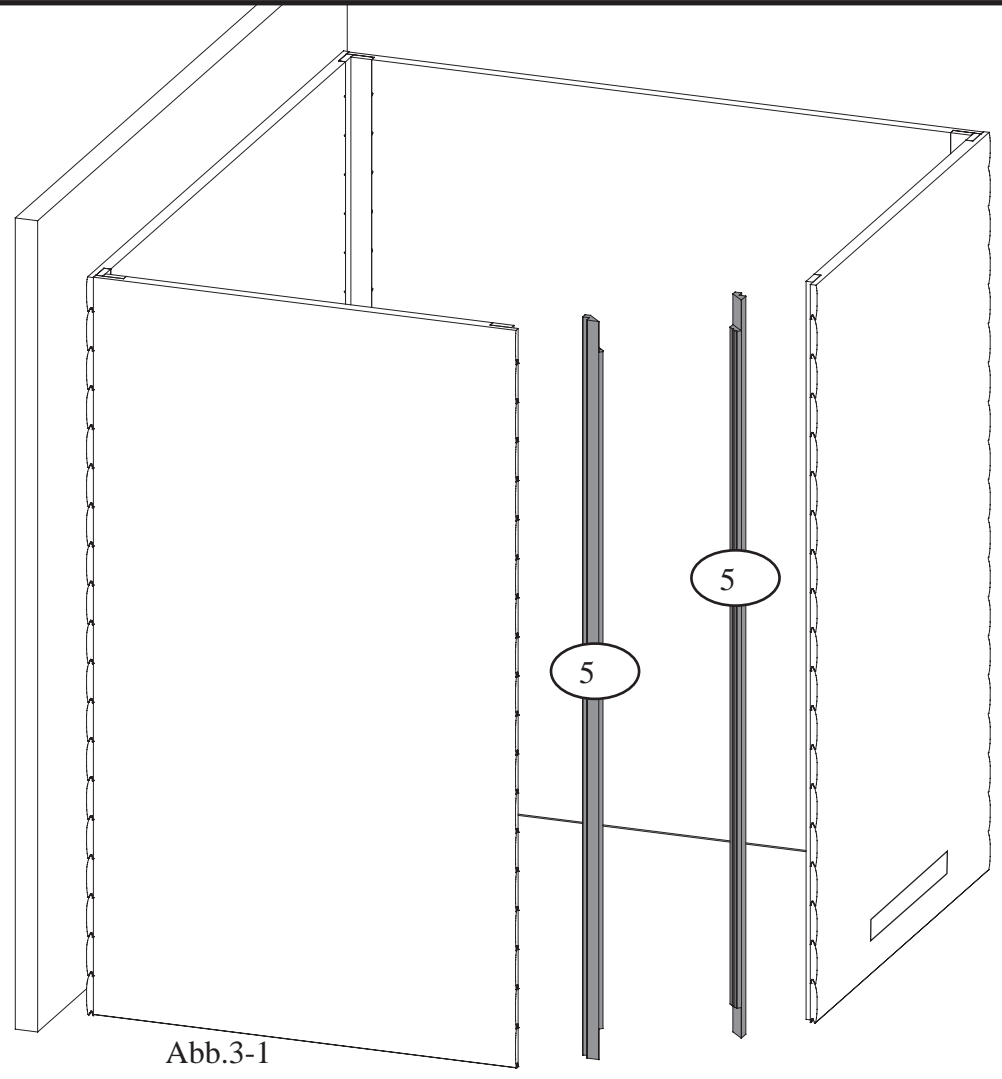

Abb.3-3



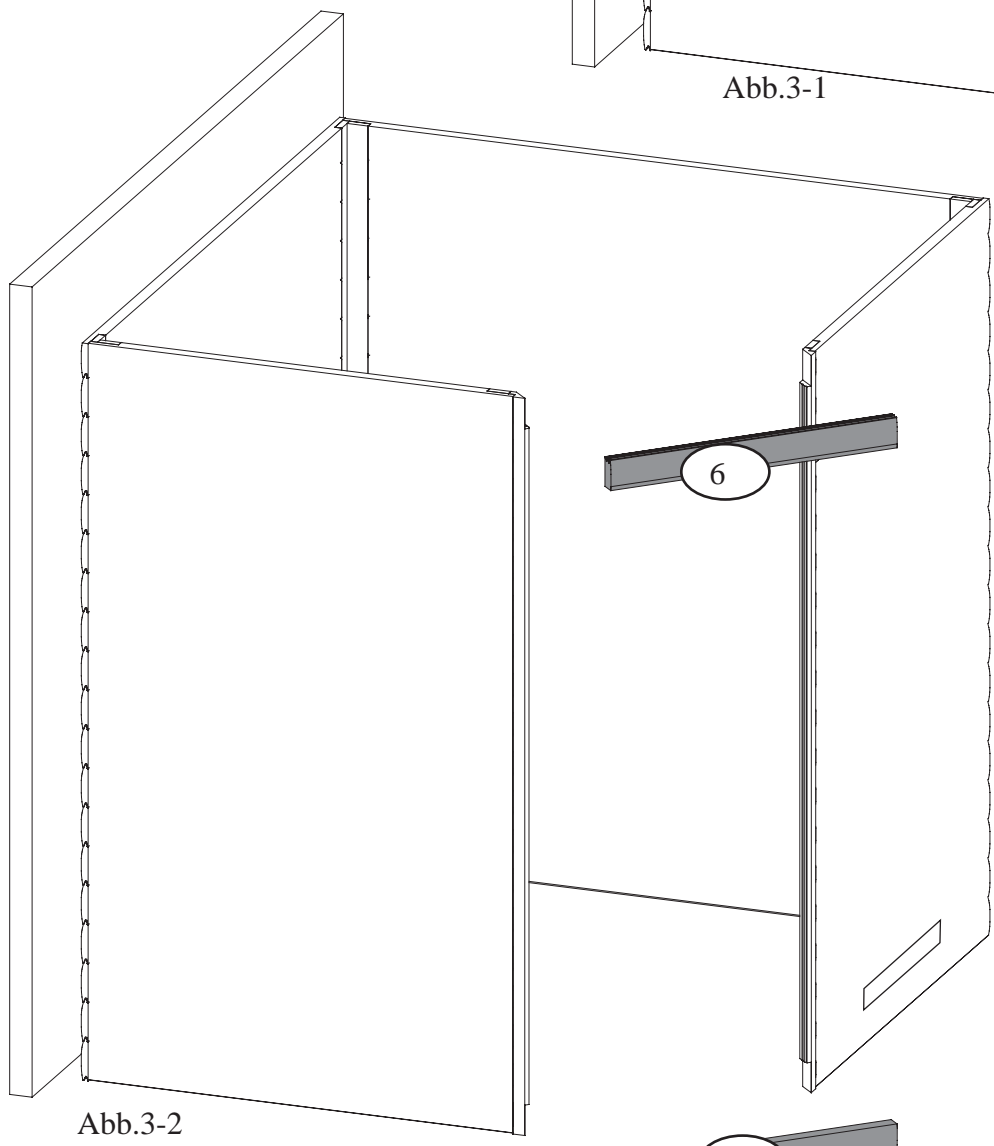

Abb.4-1

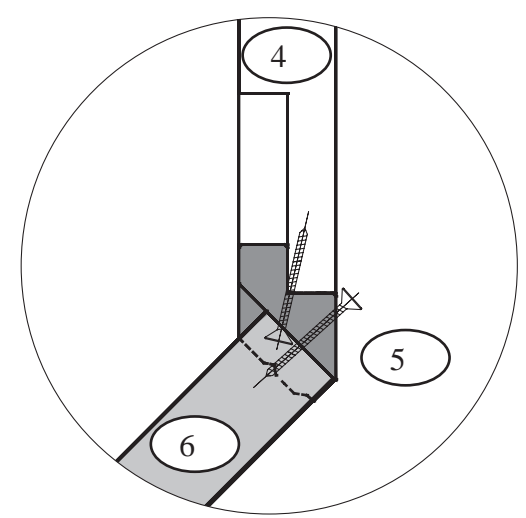
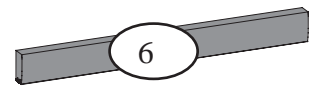
 Einbau Glastür
 Montage porte en verre
 Installation of glass door
 Montage van de glazen deur
 Montaje de la puerta de cristal
 Installazione portello di vetro



01 — **03**

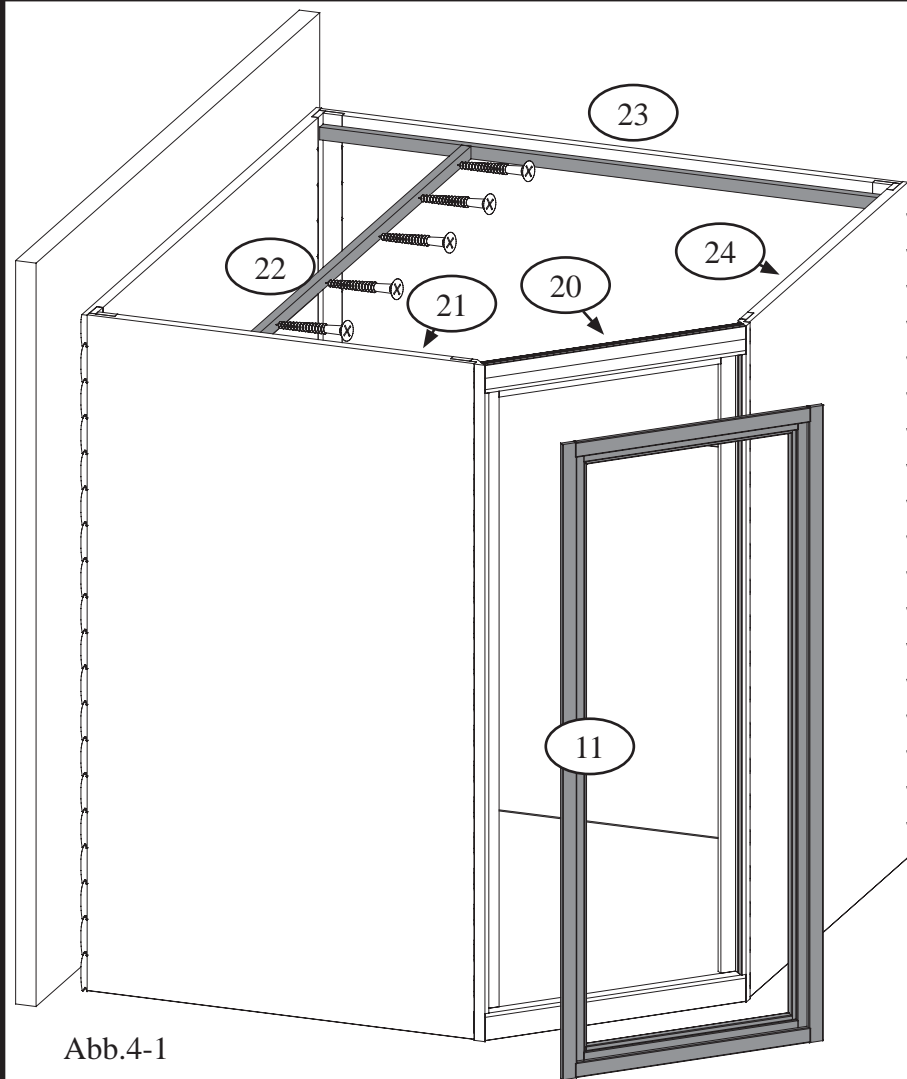



Abb.4-2



Abb.4-3

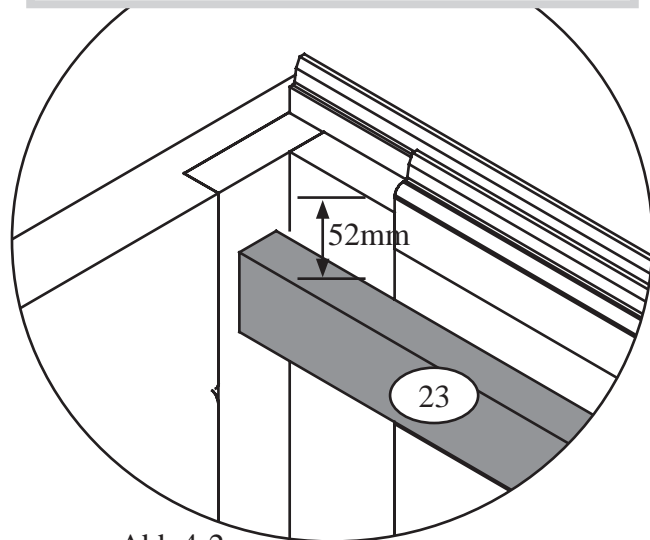

Abb.4-4

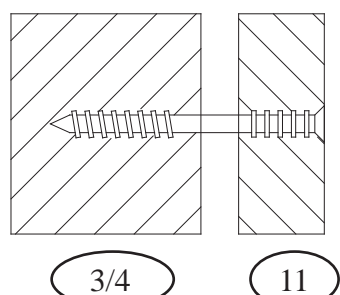
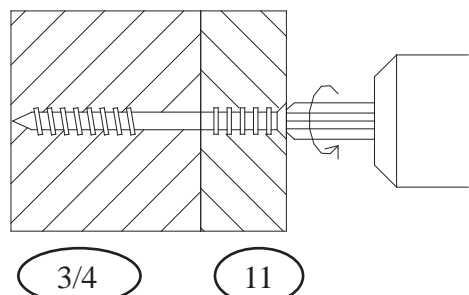
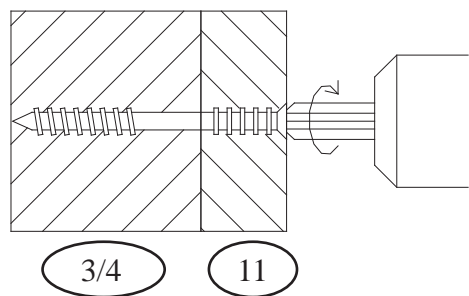

Abb.5-1

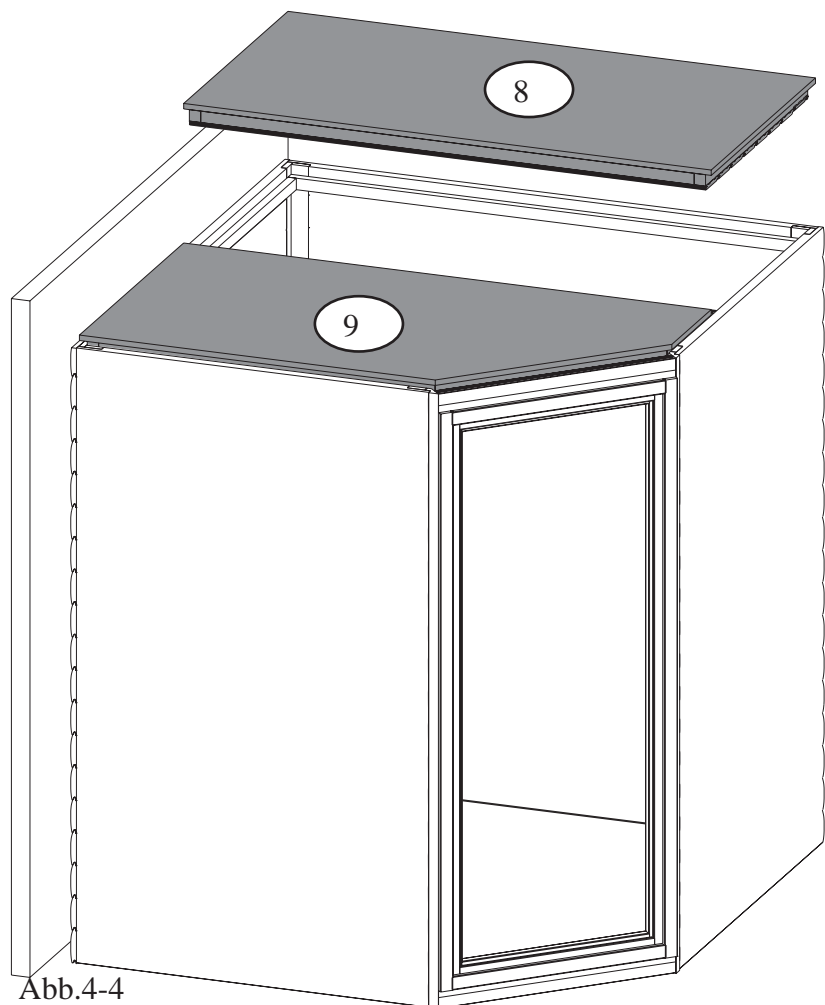

Abb.5-2

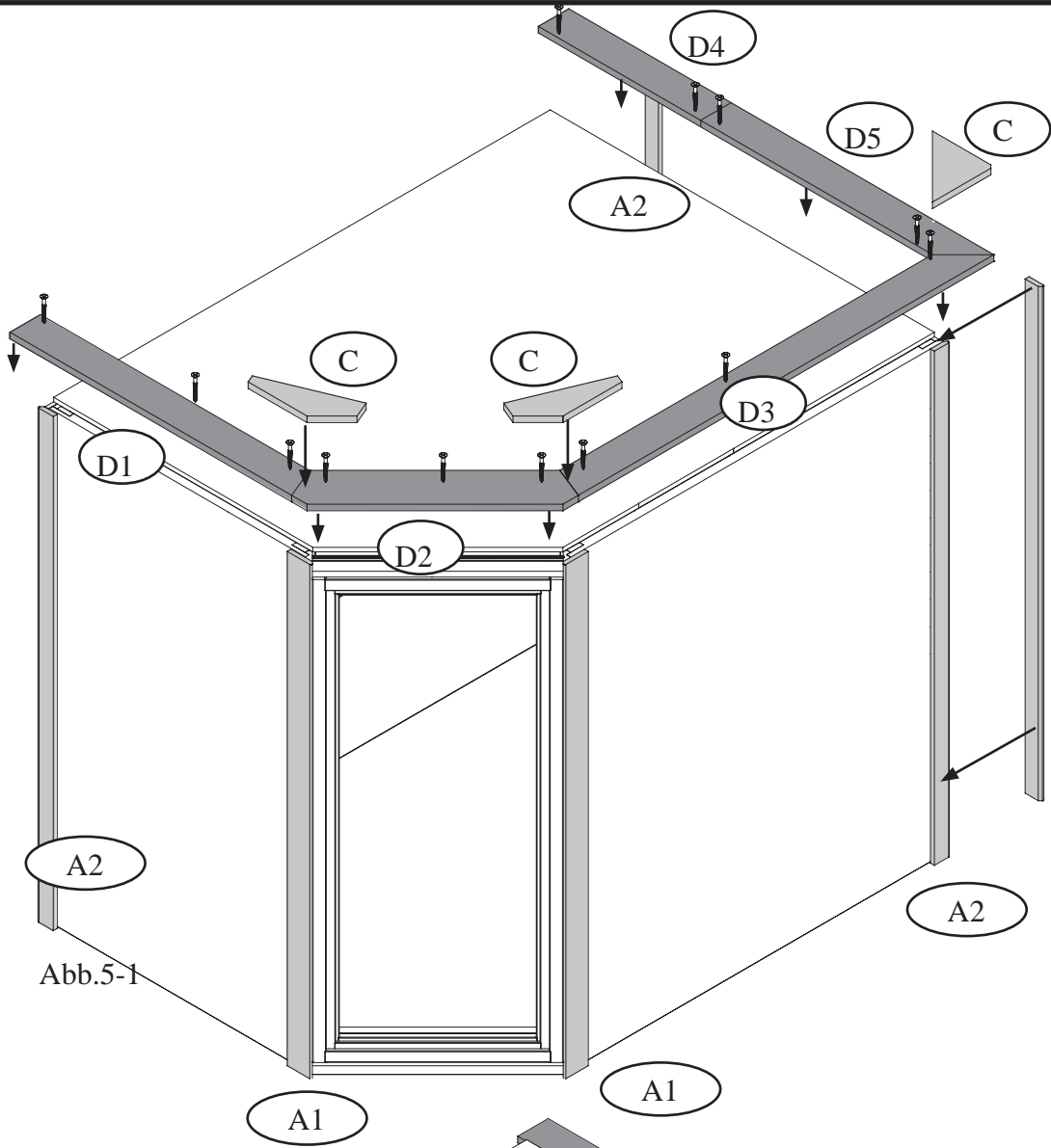

Abb.5-3

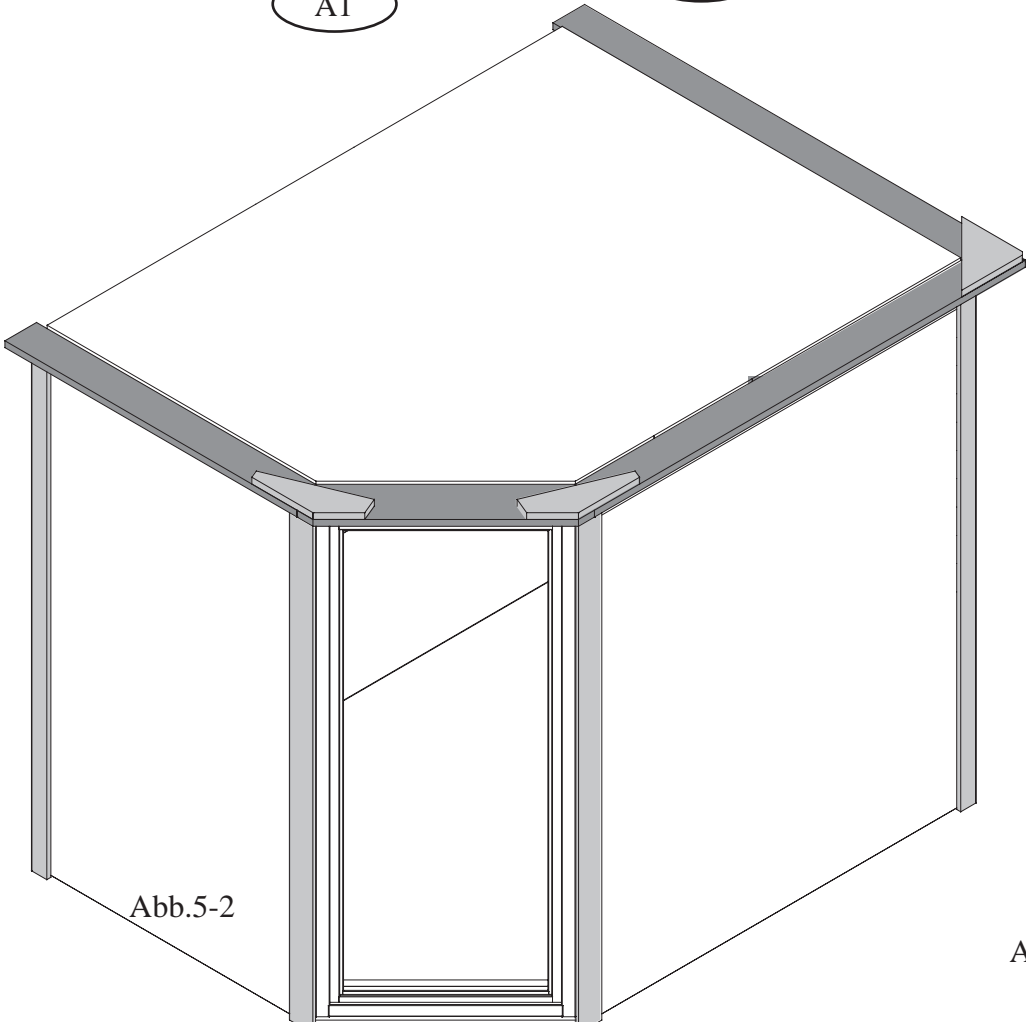

Abb.5-4

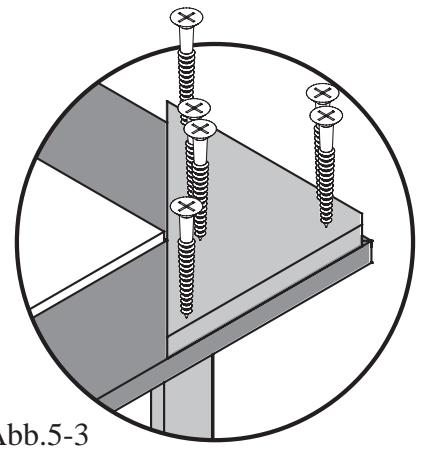

Abb.6-1

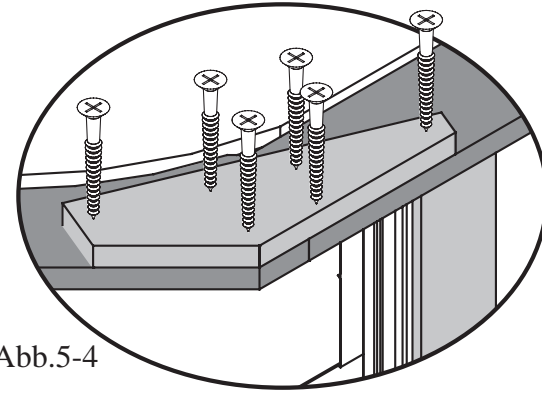

Abb.6-2



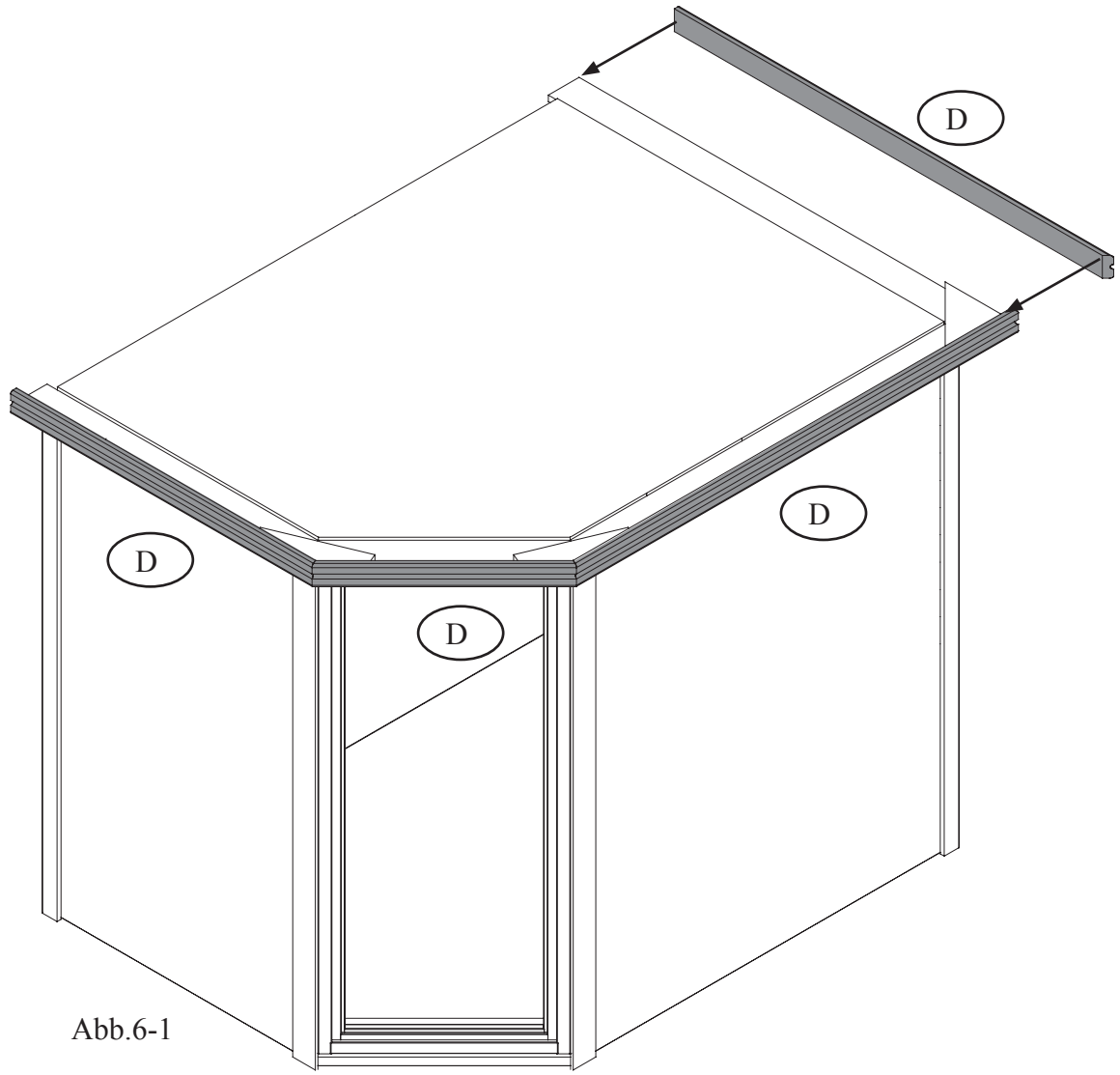
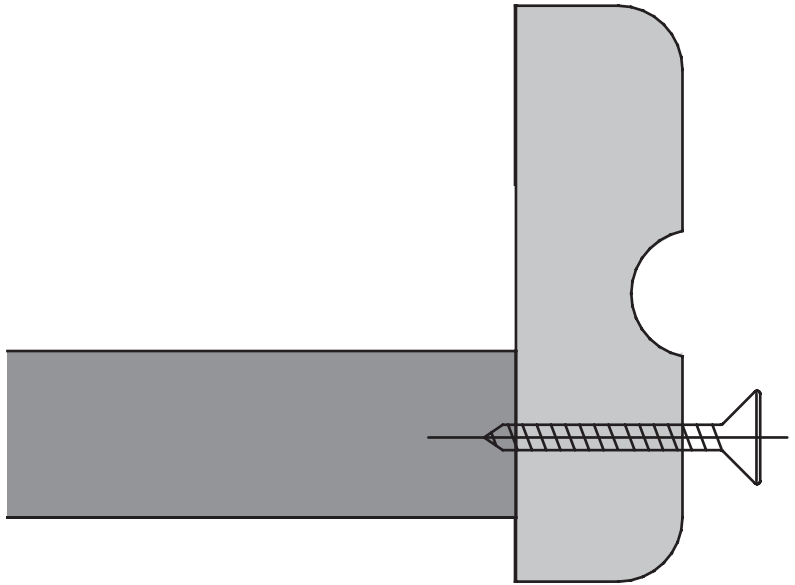
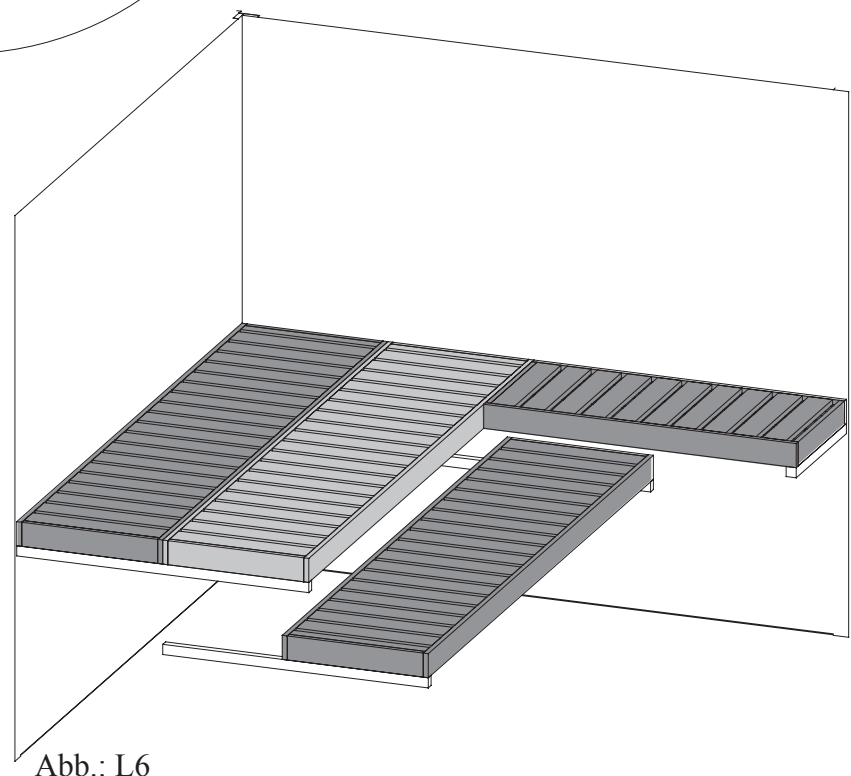
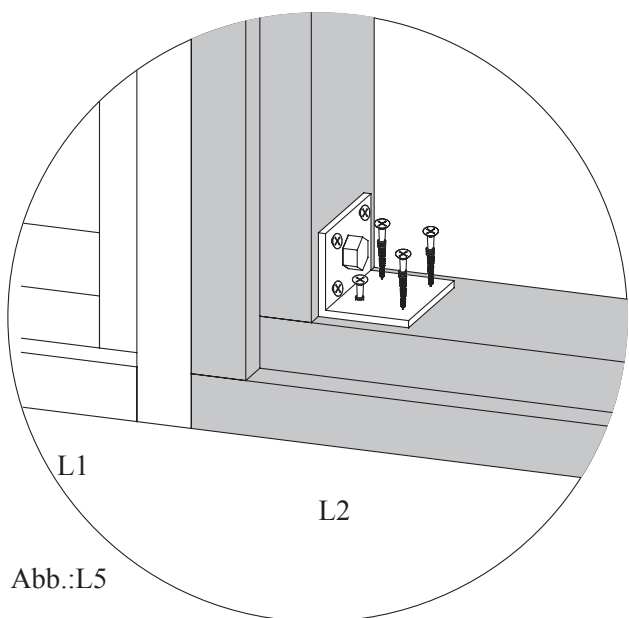
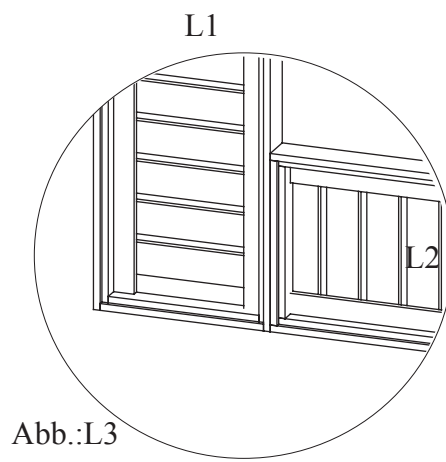
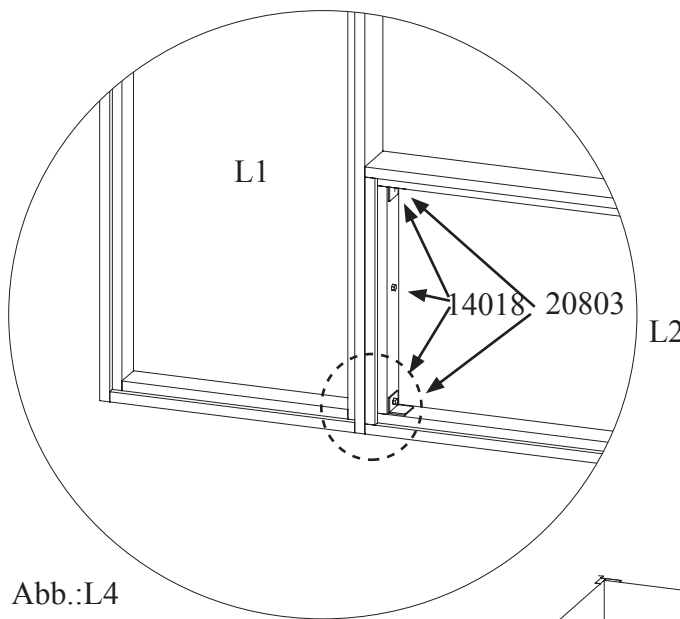
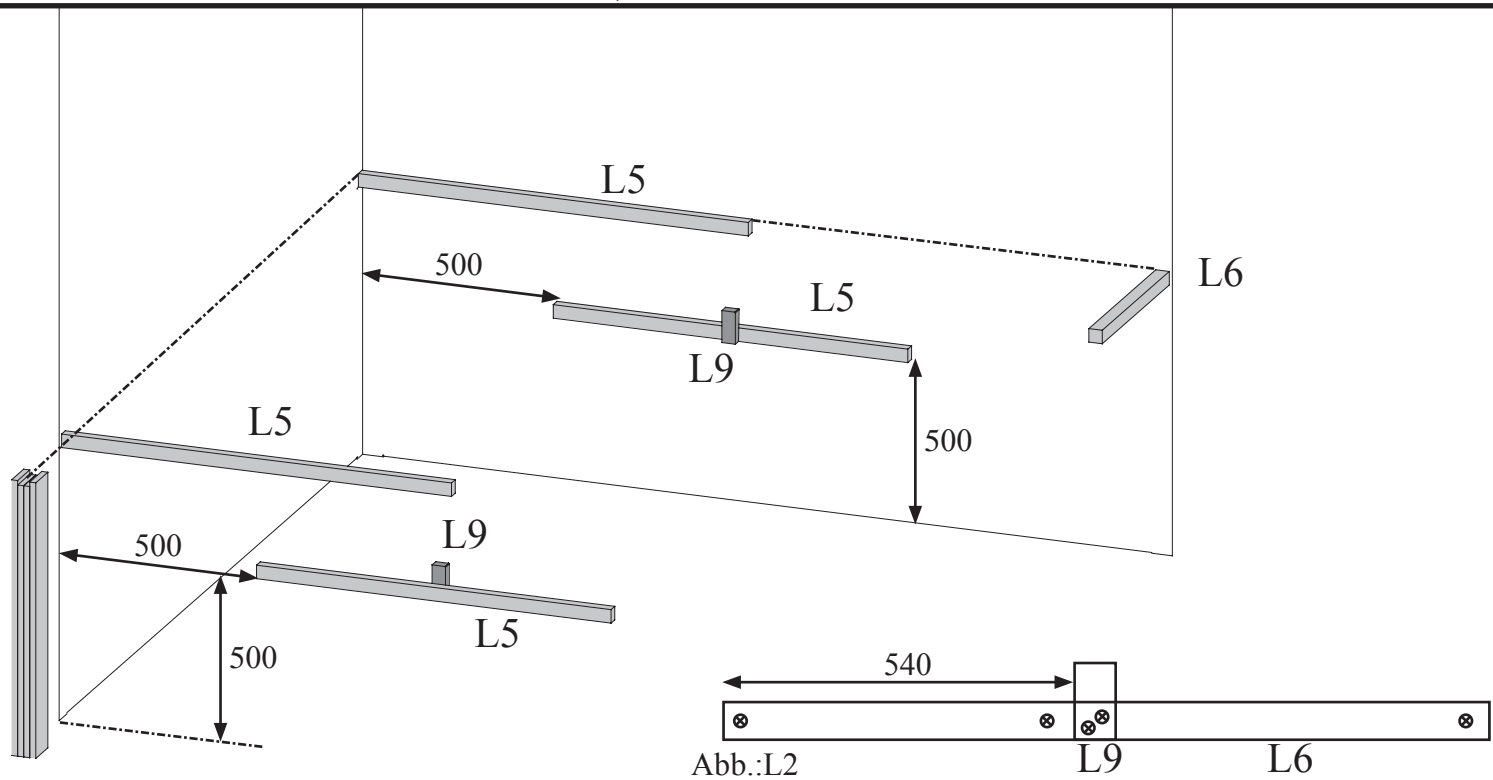



Abb.: L7



Abb.: L8

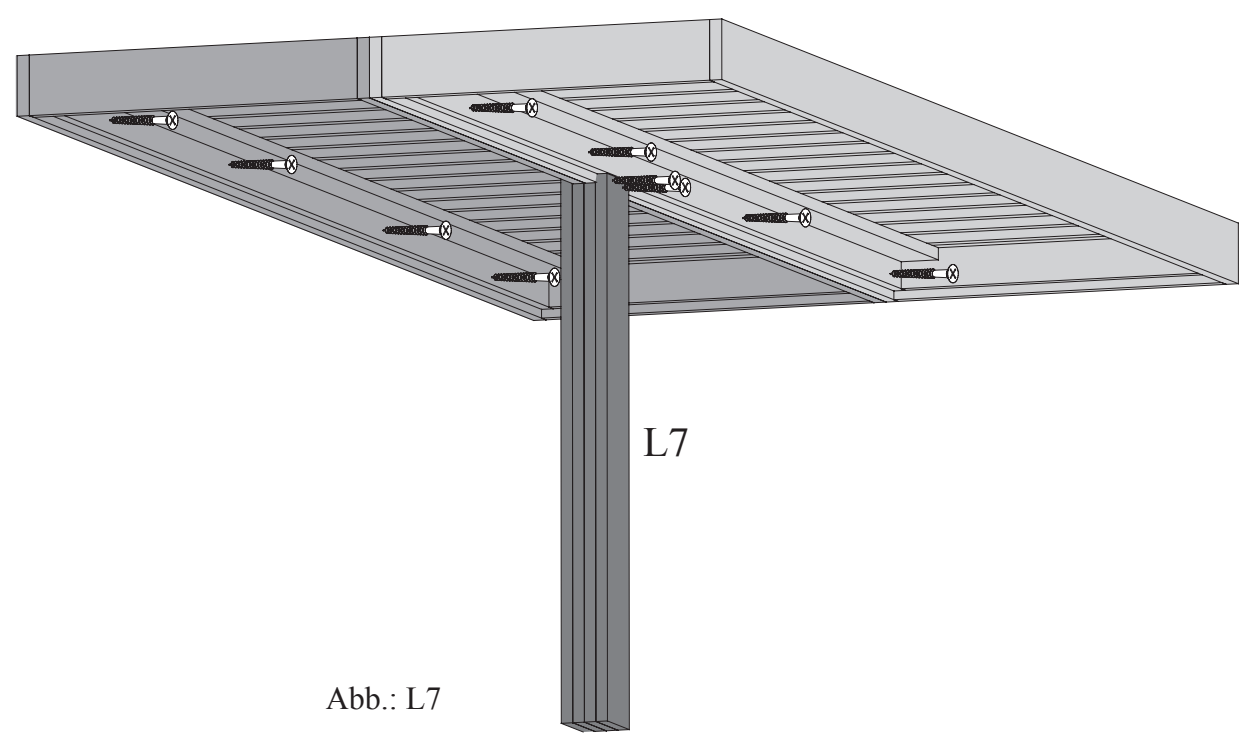

Abb. O 1



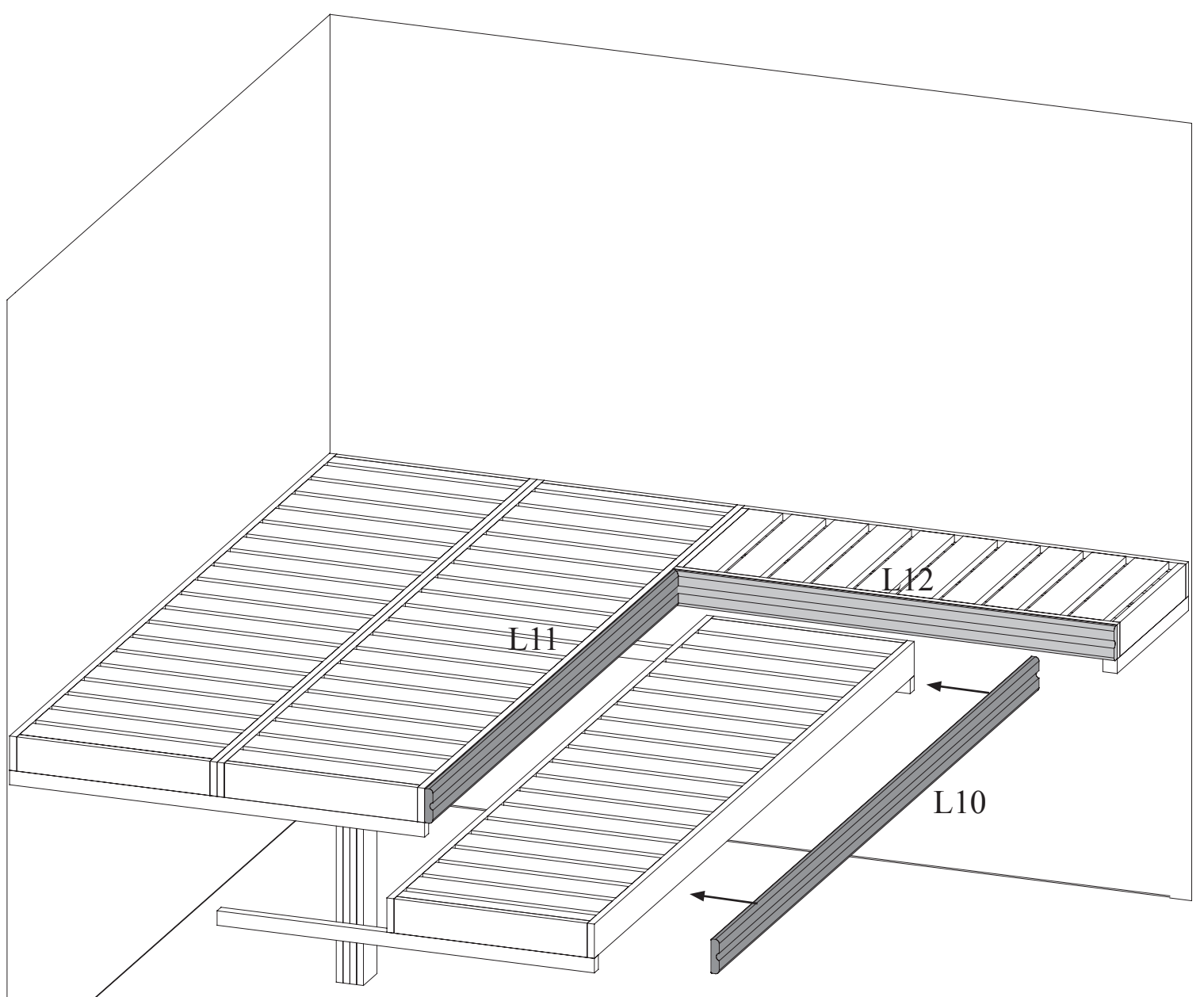



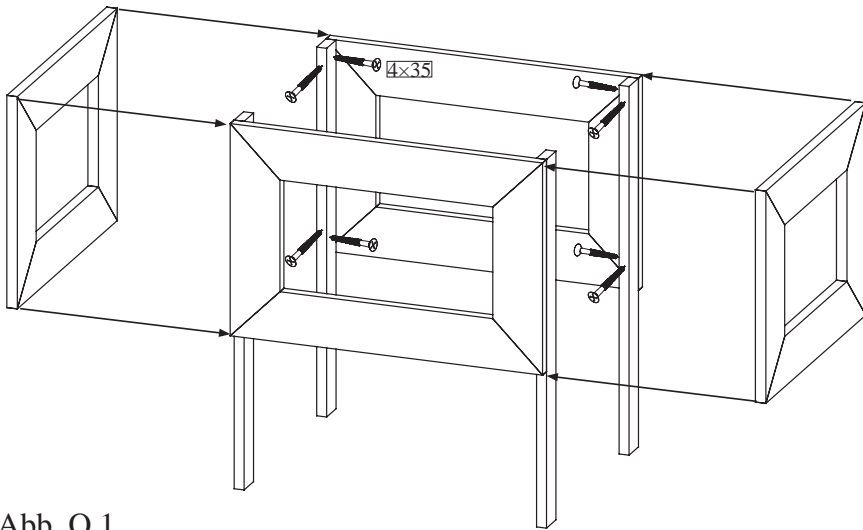

Abb. O 2

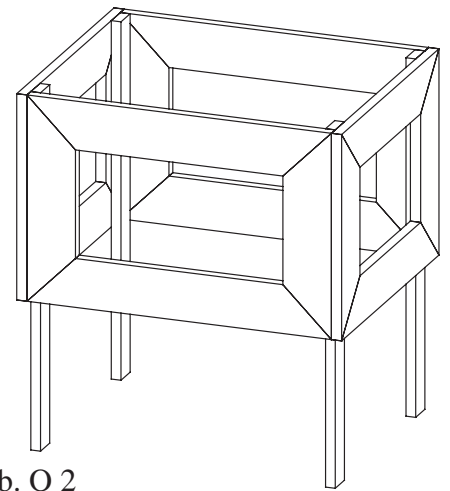
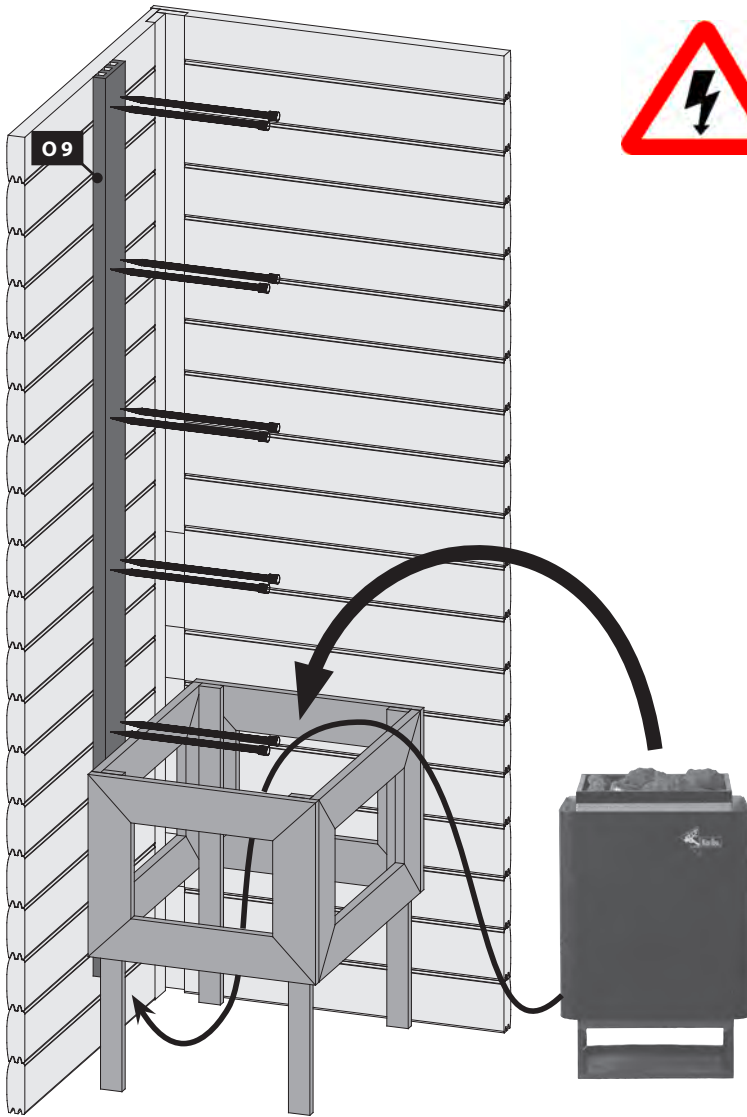

-  Einbau Glastür
-  Montage porte en verre
-  Installation of glass door
-  Montage van de glazen deur
-  Montaje de la puerta de cristal
-  Installazione portello di vetro

!!! 04 – 08 !!!



Abb.:O3



Abb.:O4

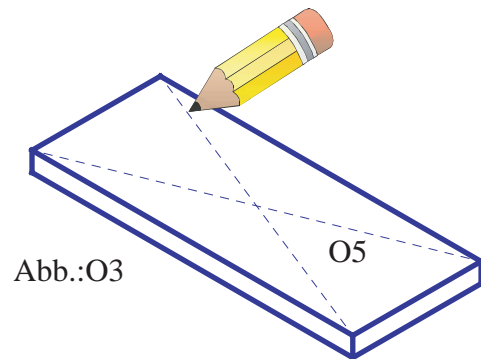

Abb.:O5

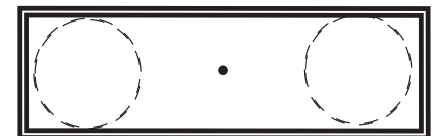

Abb.:O6

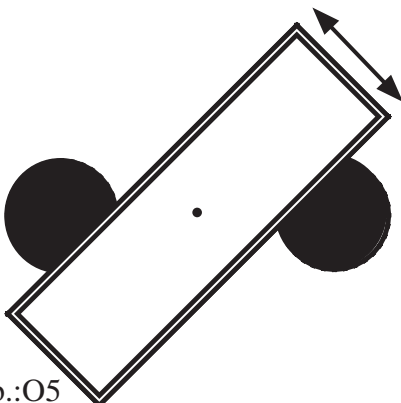

Abb.:O7

 Einbau Glastür

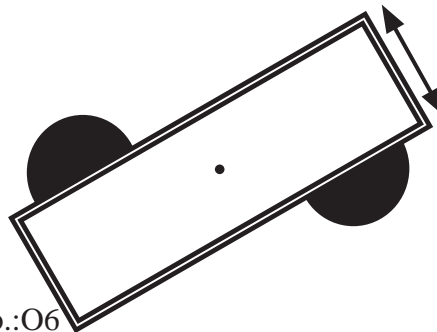
 Installation of glass door

 Montaje de la puerta de cristal

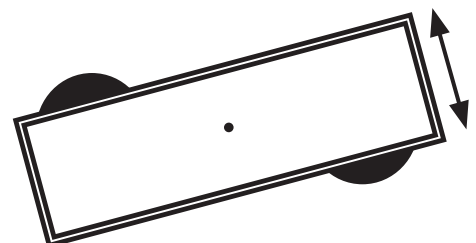
 Montage porte en verre

 Montage van de glazen deur

 Installazione portello di vetro

01

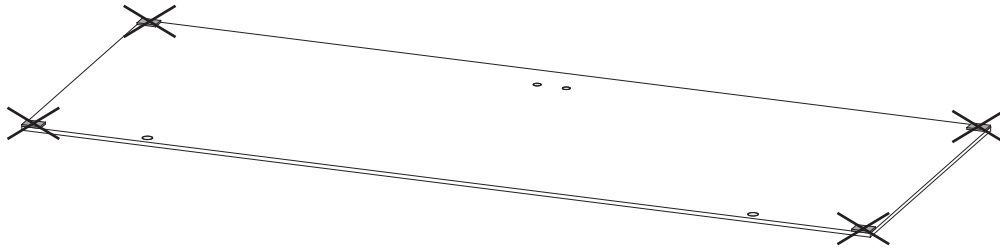

02

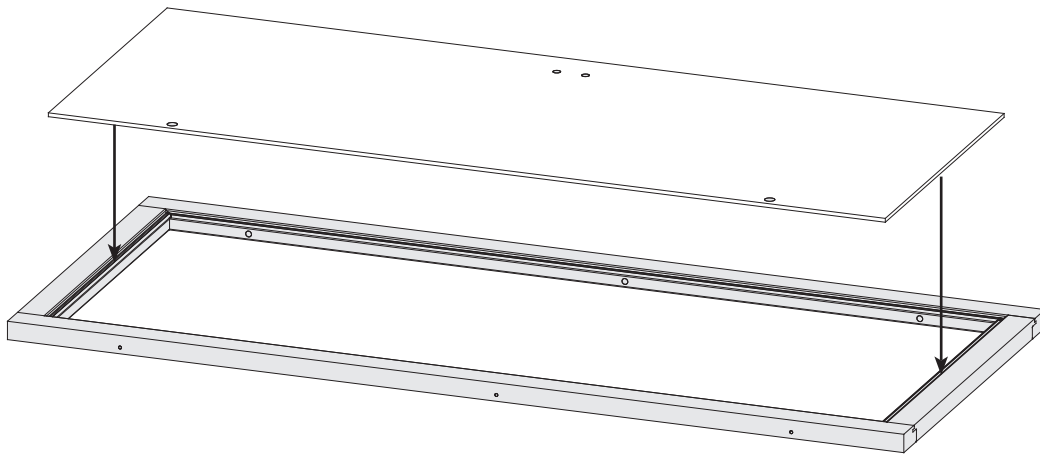

03

 Das Saunätürglas im Türrahmen ausrichten!

 Bien aligner le verre à vitre!

 To start building up the door you need to center the glass in the wooden frame!

 Plaats het glas van de sauna deur in het midden van het kozijn!

 ¡Centrar la puerta de cristal dentro del marco!

 Allineare il vetro dello sportello sauna al telaio della porta!

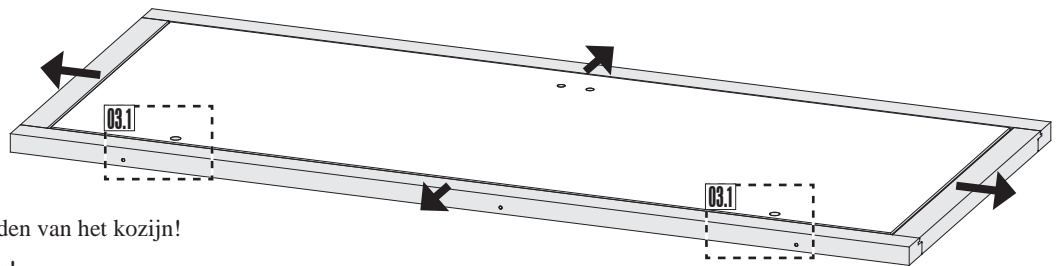

03.1-1

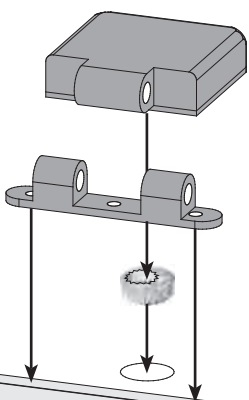

03.1-2

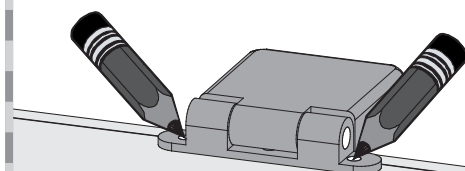

03.1-3

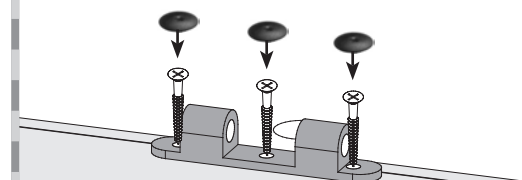

 Einbau Glastür

 Installation of glass door

 Montaje de la puerta de cristal

 Montage porte en verre

 Montage van de glazen deur

 Installazione portello di vetro

04

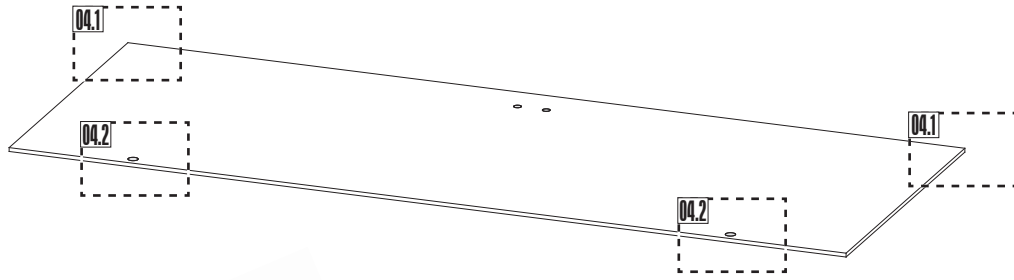

04.1-1

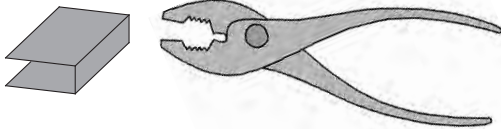

04.1-2

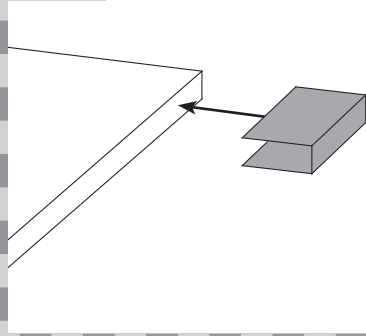

04.1-3

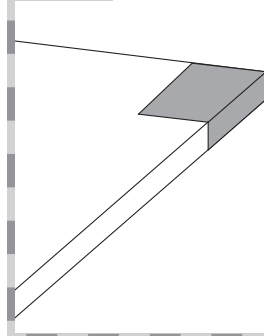

04.2-1

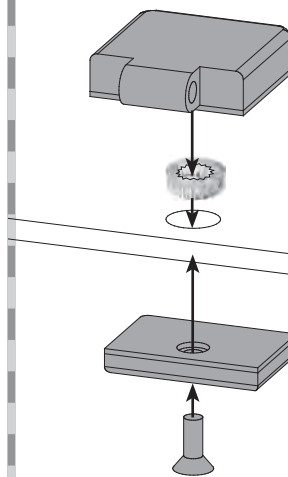

04.2-2

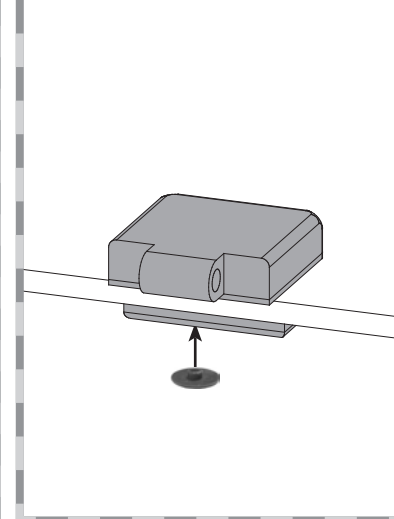

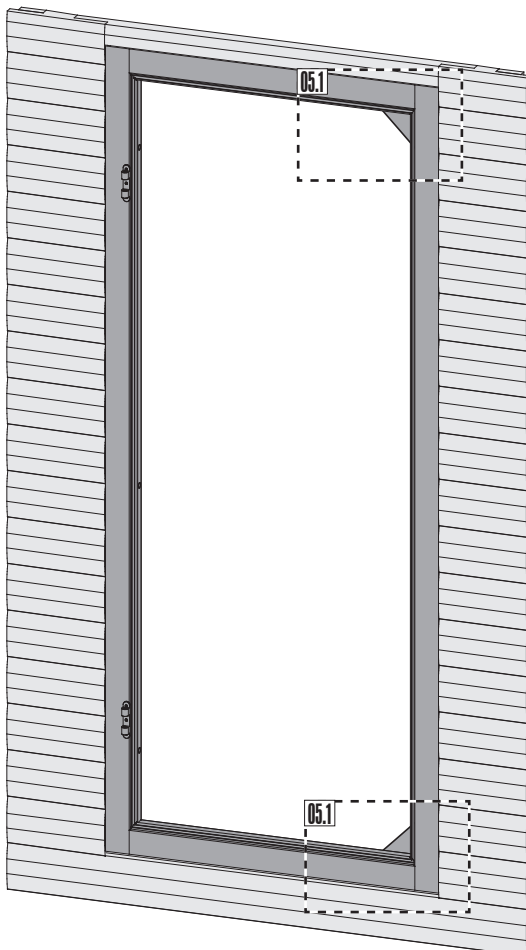

05





 Achtung: Alle Verstell-Excenter müssen in der Glasscheibe die gleiche Grundstellung haben!

 Attention: Tous les excentres de positionnement doivent avoir la même position de base dans la vitre!

 Attention: All adjustable eccentrics must have the same basic adjustment in the glass panel!

 Attentie: alle excentrische verstelelementen moeten in dezelfde stand in de glasplaat worden geplaatst!

 Atención: Todos los excéntricos regulables tienen que tener la misma posición base en la hoja de cristal.

 Attenzione: Tutti gli eccentrici di regolazione devono avere la stessa posizione base nella lastra di vetro!

05.1-1



05.1-2



 Einbau Glastür

 Installation of glass door

 Montaje de la puerta de cristal

 Montage porte en verre

 Montage van de glazen deur

 Installazione portello di vetro

06

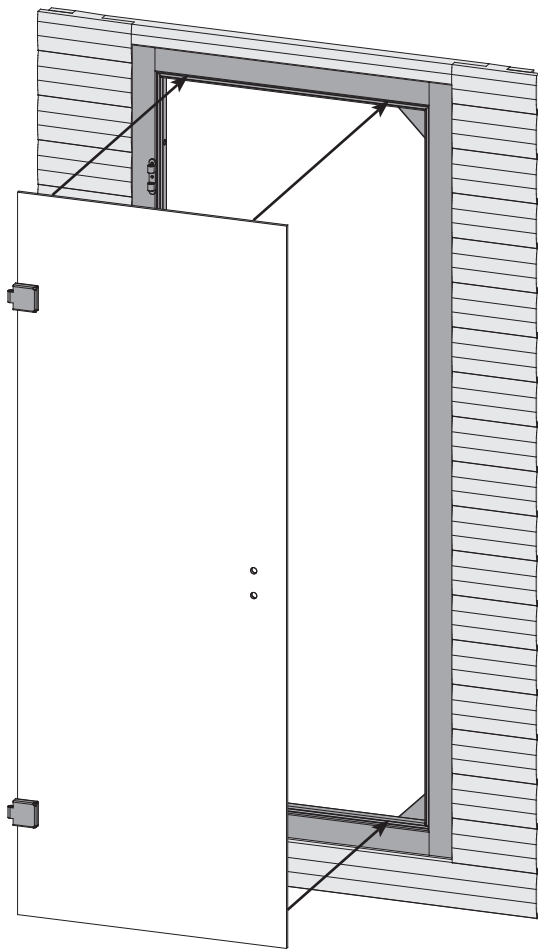

07

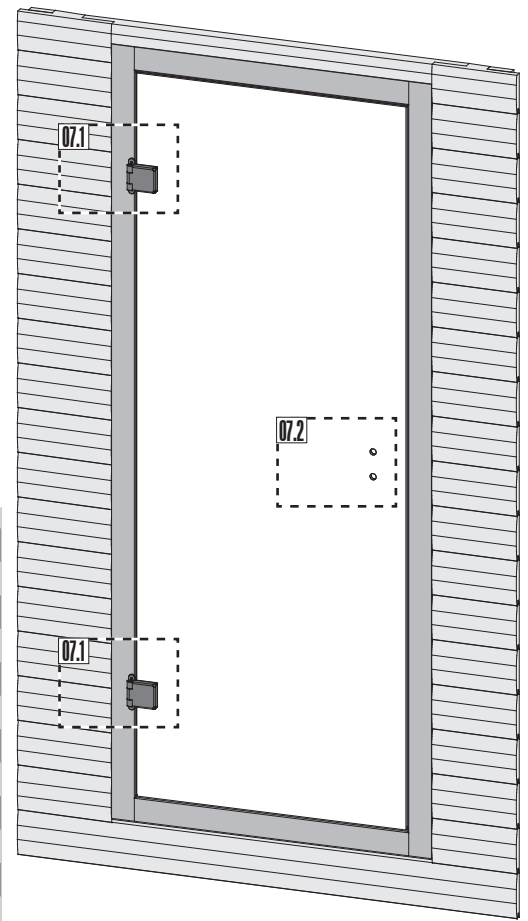

07.1

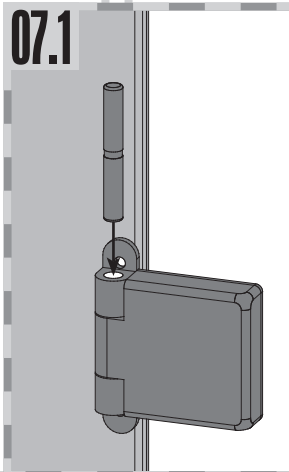

07.2-1

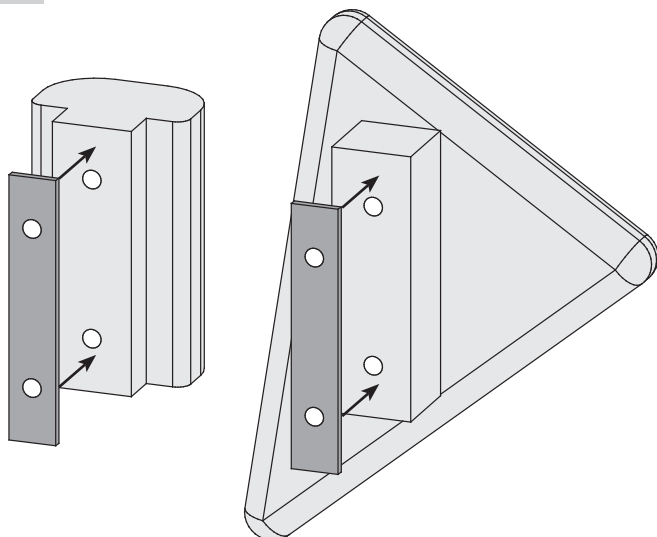

07.2-2

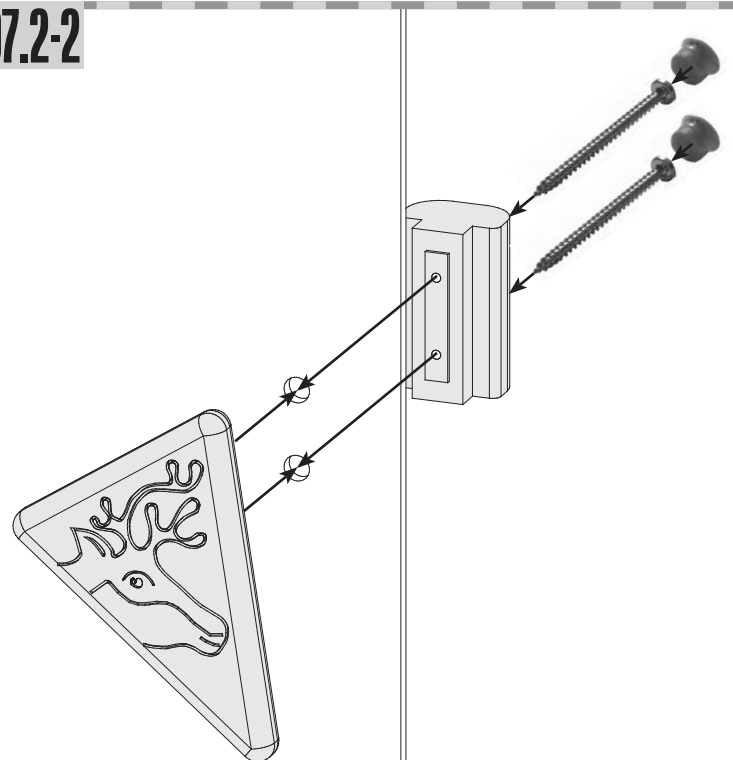

 **Einbau Glastür**

 **Installation of glass door**

 **Montaje de la puerta de cristal**

 **Montage porte en verre**

 **Montage van de glazen deur**

 **Installazione portello di vetro**

08

 **Seitenverstellung + Höhenverstellung**

Achtung: Alle Verstell-Excenter müssen in der Glasscheibe die gleiche Grundstellung haben!

 **Positionnement latéral + positionnement hauteur**

Attention: Tous les excenteurs de positionnement doivent avoir la même position de base dans la vitre!

 **Lateral adjustment + height adjustment**

Attention: All adjustable eccentrics must have the same basic adjustment in the glass panel!

 **Zijverstelling + hoogteverstelling**

Attentie: alle excentrische verstelelementen moeten in dezelfde stand in de glasplaat worden geplaatst!

 **Regulación lateral + regulación de la altura**

Atención: Todos los excéntricos regulables tienen que tener la misma posición base en la hoja de cristal.

 **Regolazione laterale + regolazione dell'altezza**

Attenzione: Tutti gli eccentrici di regolazione devono avere la stessa posizione base nella lastra di vetro!

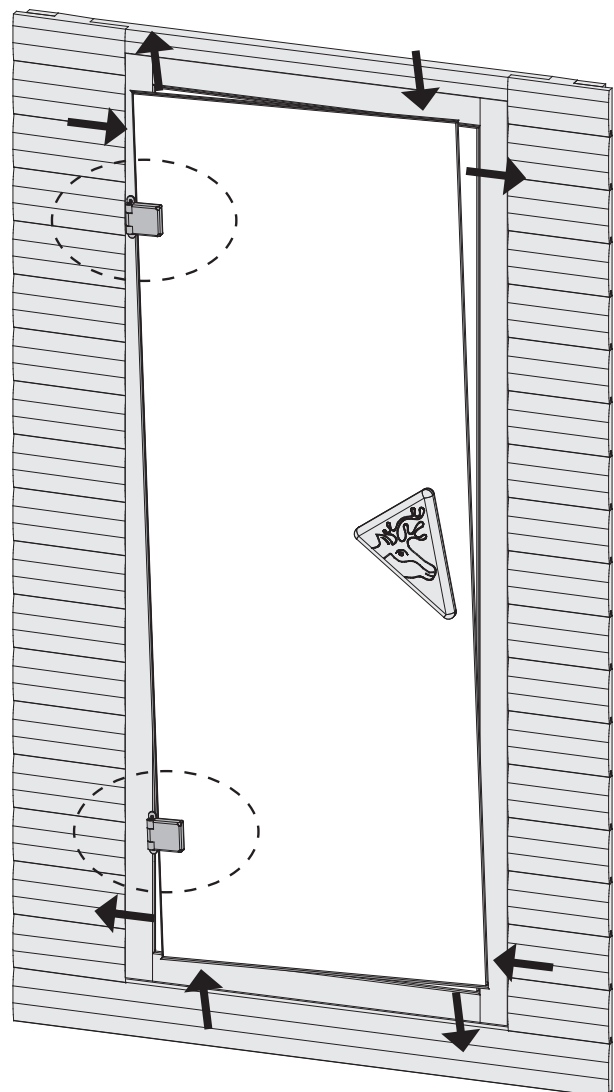

01

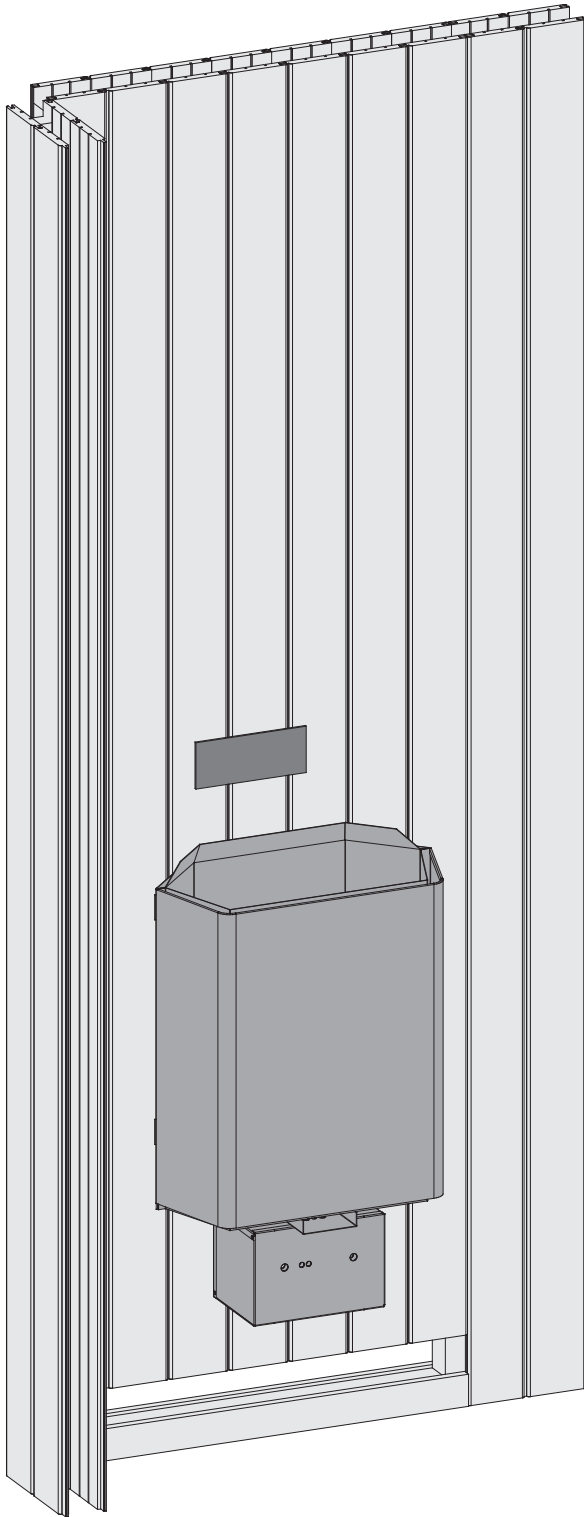

02

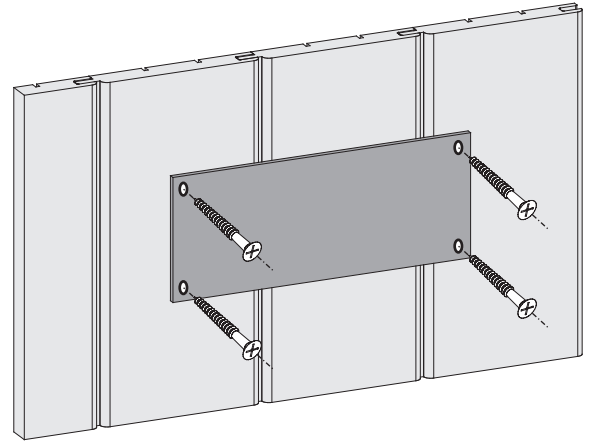

Entfernen Sie die Schutzfolie vom beiliegenden TÜV-Schild.

Lassen Sie den Saunaofen von einem zugelassenen Elektrofachmann anschließen. Dieser markiert den installierten Ofen auf dem TÜV-Schild.

Bringen Sie das TÜV-Schild an einer gut sichtbaren Stelle über dem Ofen an.



14016



 **Aufbauanleitung**

 **notice de montage**

 **Building Instructions**

 **montagehandleiding**

 **Instrucciones de construcción**

 **Istruzioni per il montaggio**

 **Service-Hotline: +49 421 38693 33**

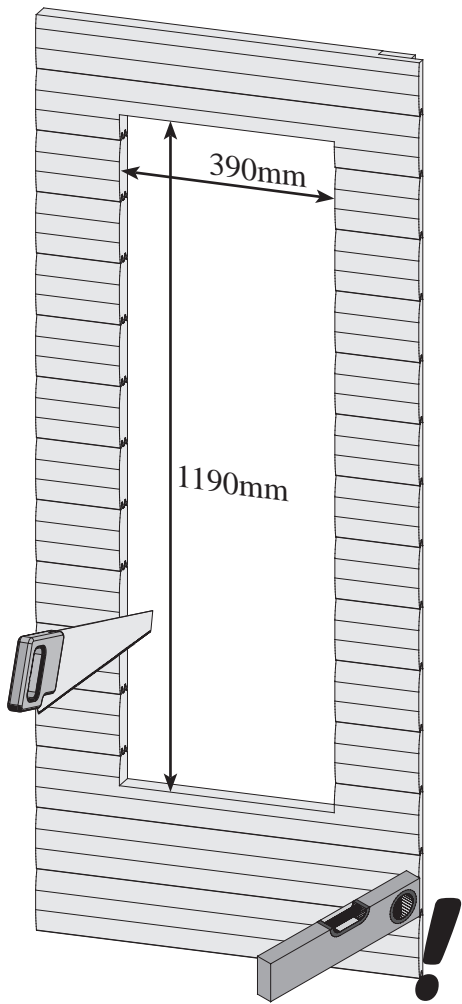
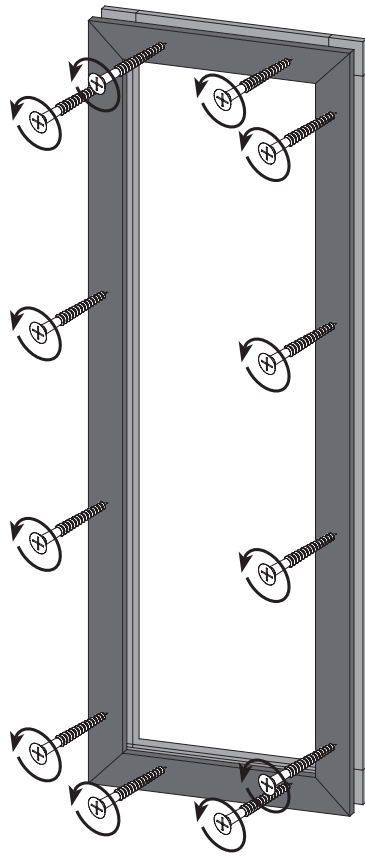
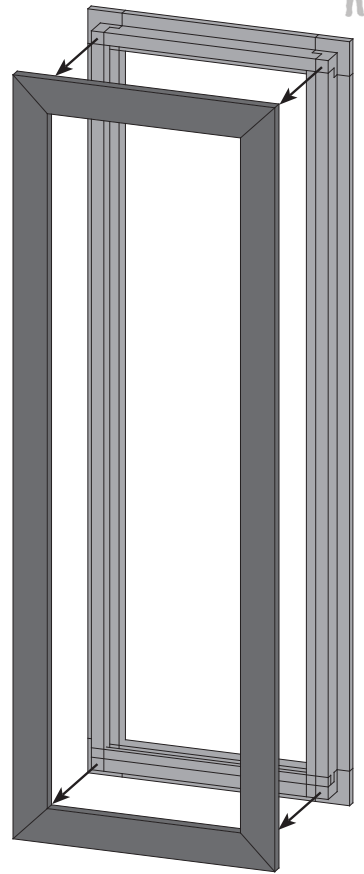
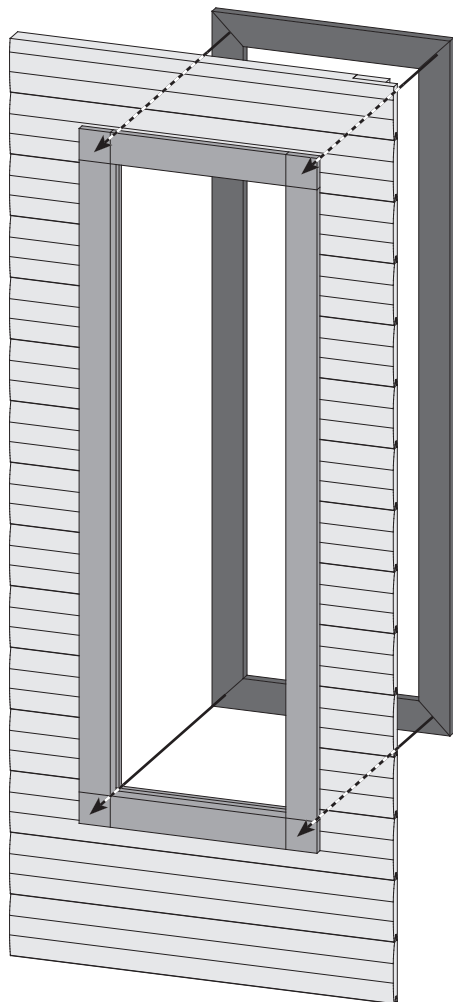
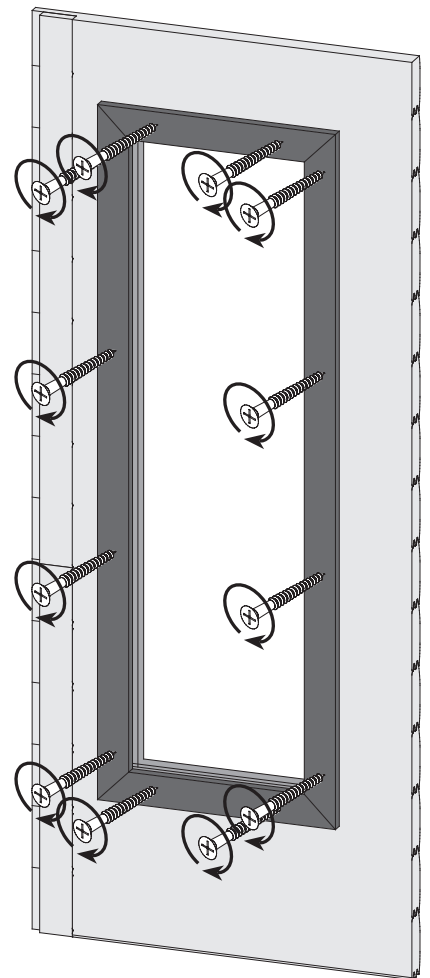
01**02****03****04****05**

50121

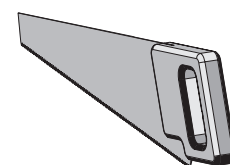
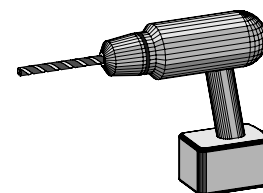
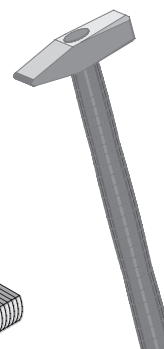
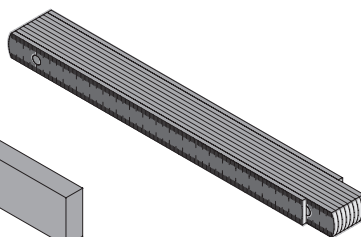
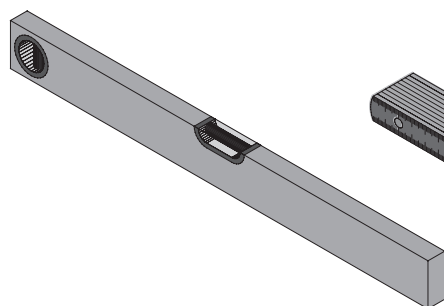
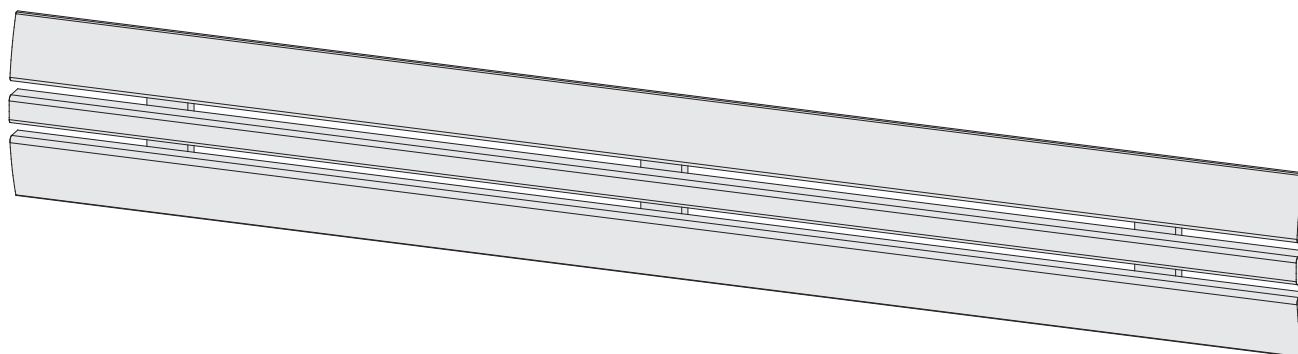

 **Aufbauanleitung**

 **notice de montage**

 **Building Instructions**

 **montagehandleiding**

 **Instrucciones de construcción**

 **Istruzioni per il montaggio**

 **Service-Hotline: +49 421 38693 33**



Vergleichen Sie zuerst die Materialliste mit Ihrem Paketinhalt! Bitte haben Sie Verständnis, dass Beanstandungen nur im nicht aufgebauten Zustand bearbeitet werden können!



Commencez par comparer la liste du matériel avec le contenu de votre paquet! Sachez que nous traitons uniquement les réclamations concernant le matériel à l'état non monté!



First compare the list of materials with your package contents! Please understand that complaints can be processed in the non-built status only!



Vergelijk eerst de lijst van materialen met de inhoud van uw pakket! Reclamaties kunnen alleen in behandeling worden genomen zolang de onderdelen nog niet zijn gemonteerd!



En primer lugar, compare la lista de material con el contenido del paquete. Rogamos entienda que las reclamaciones sólo pueden ser tramitadas antes de montar el objeto!



Confrontate questa distinta materiali prima con il contenuto del pacchetto! Vi preghiamo di comprendere che eventuali reclami possono essere accolti solo prima del montaggio!



50121

1 x B1	2238 x 200 x 43mm	ID 50121
2 x B2	160 x 42 x 28mm	ID 25058
4 x	4 x 50mm	ID 3688
4 x	4 x 70mm	ID 3689

01

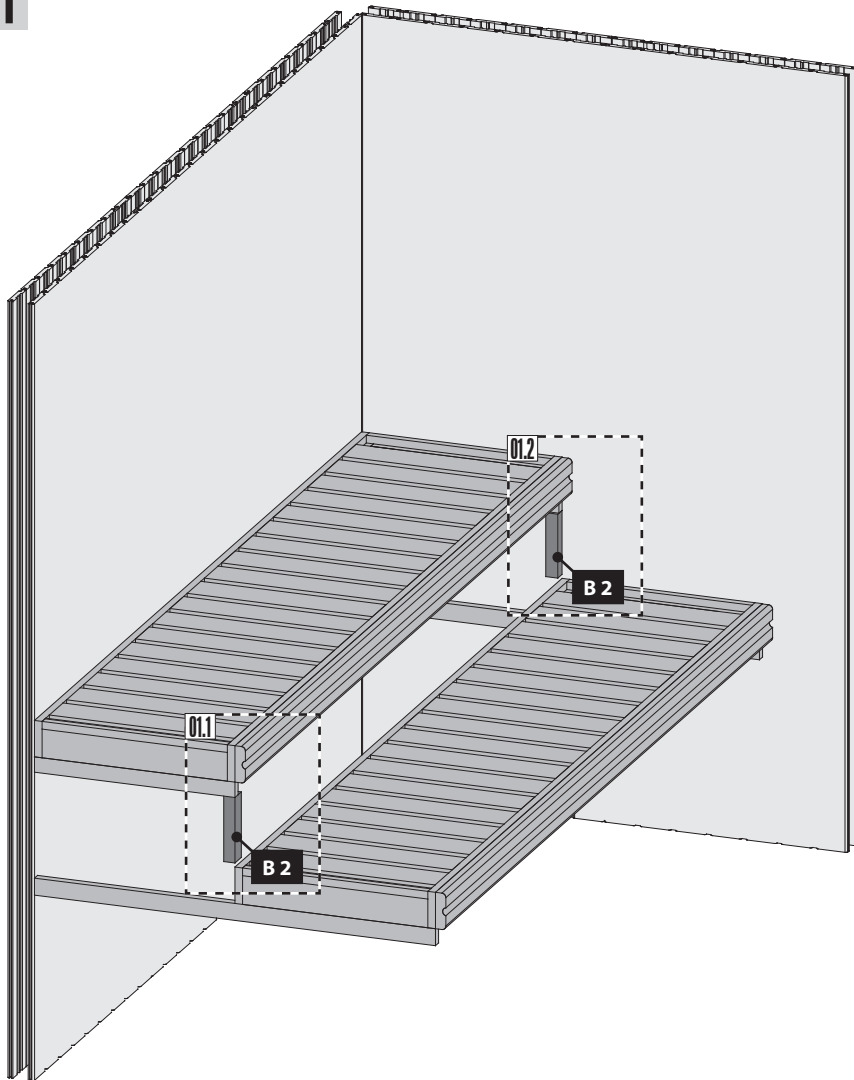

01.1

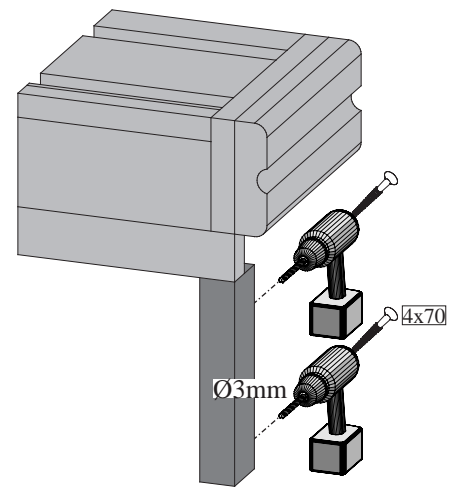

01.2

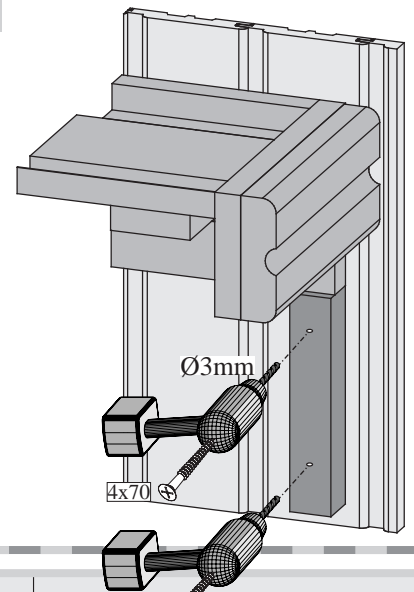

02

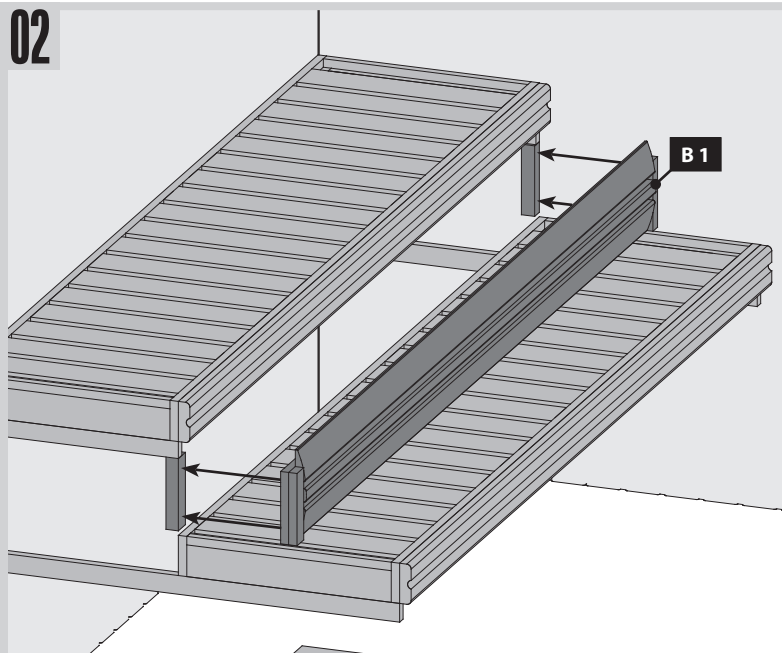

03

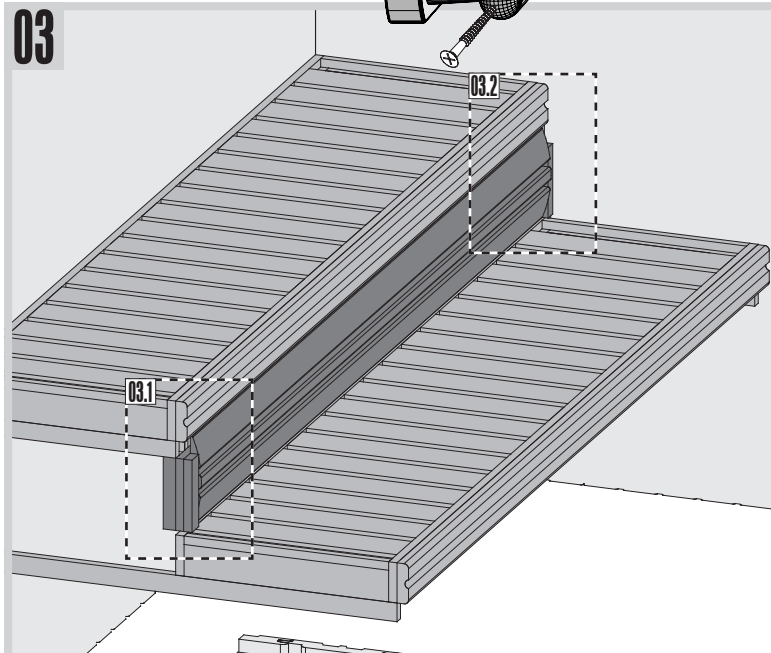

03.1

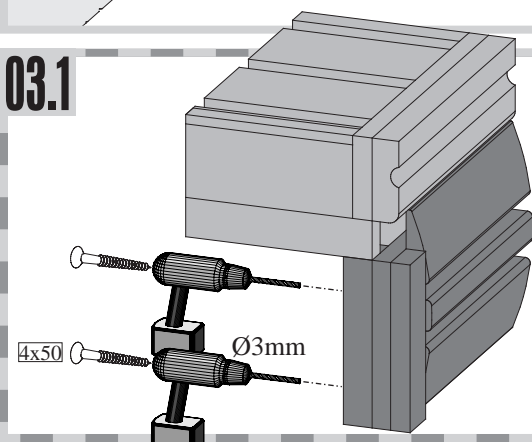

03.2

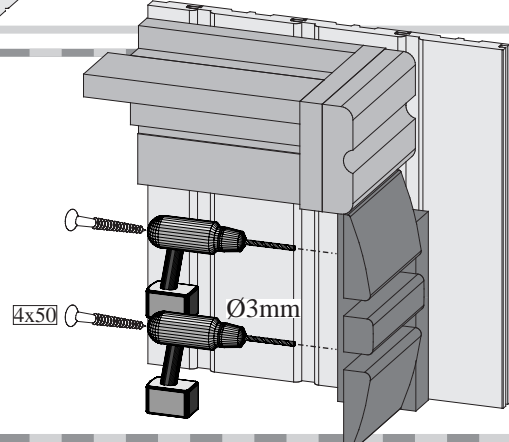

50425

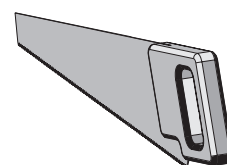
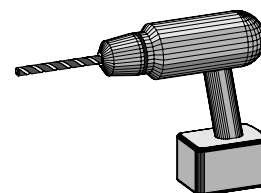
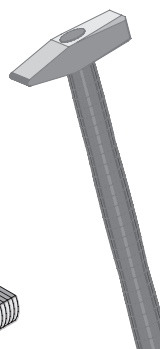
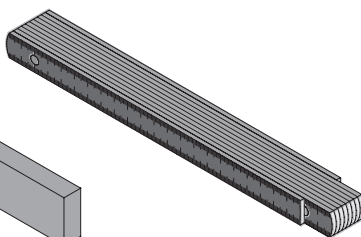
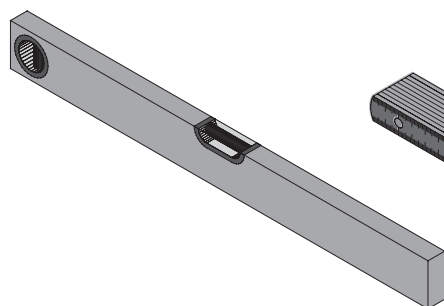
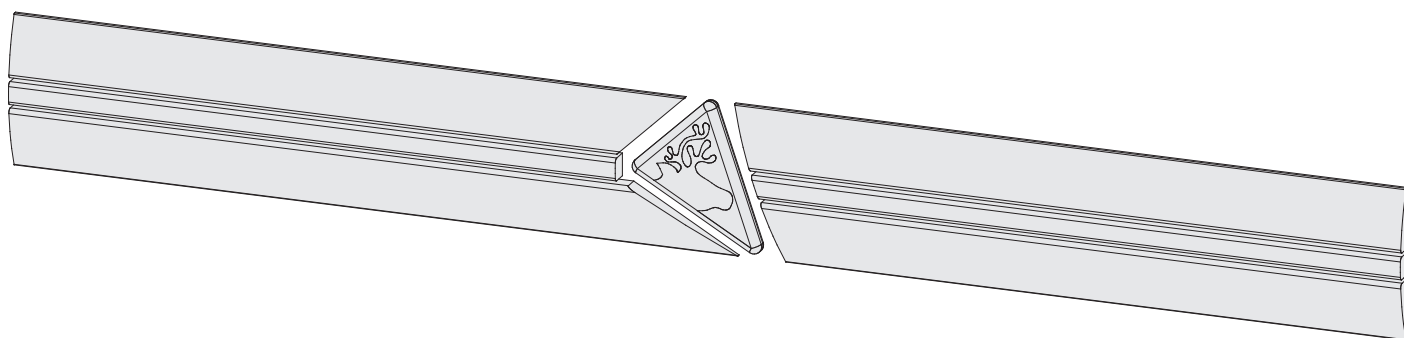

 **Aufbauanleitung**

 **notice de montage**

 **Building Instructions**

 **montagehandleiding**

 **Instrucciones de construcción**

 **Istruzioni per il montaggio**

 **Service-Hotline: +49 421 38693 33**



Vergleichen Sie zuerst die Materialliste mit Ihrem Paketinhalt! Bitte haben Sie Verständnis, dass Beanstandungen nur im nicht aufgebauten Zustand bearbeitet werden können!



Commencez par comparer la liste du matériel avec le contenu de votre paquet! Sachez que nous traitons uniquement les réclamations concernant le matériel à l'état non monté!



First compare the list of materials with your package contents! Please understand that complaints can be processed in the non-built status only!



Vergelijk eerst de lijst van materialen met de inhoud van uw pakket! Reclamaties kunnen alleen in behandeling worden genomen zolang de onderdelen nog niet zijn gemonteerd!



En primer lugar, compare la lista de material con el contenido del paquete. Rogamos entienda que las reclamaciones sólo pueden ser tramitadas antes de montar el objeto!



Confrontate questa distinta materiali prima con il contenuto del pacchetto! Vi preghiamo di comprendere che eventuali reclami possono essere accolti solo prima del montaggio!



50425

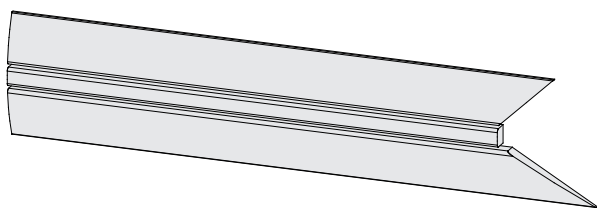

1 x R1

961 x 200 x 53mm

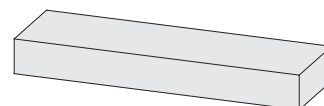

1 x B1

100 x 30 x 30mm

ID 60197

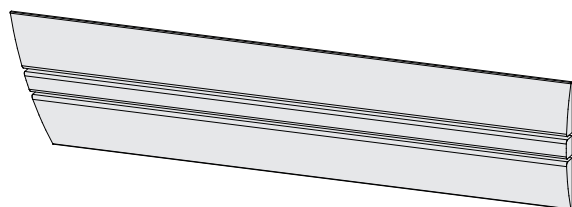

1 x R2

892 x 200 x 53mm

1 x

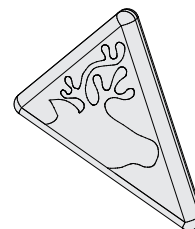

ID 26713

20 x S1



ID 26116

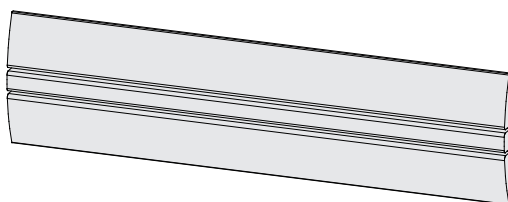

1 x R3

1413 x 200 x 53mm



20 x

4,5 x 50mm

ID 27179

2 x

4,5 x 70mm

ID 27178

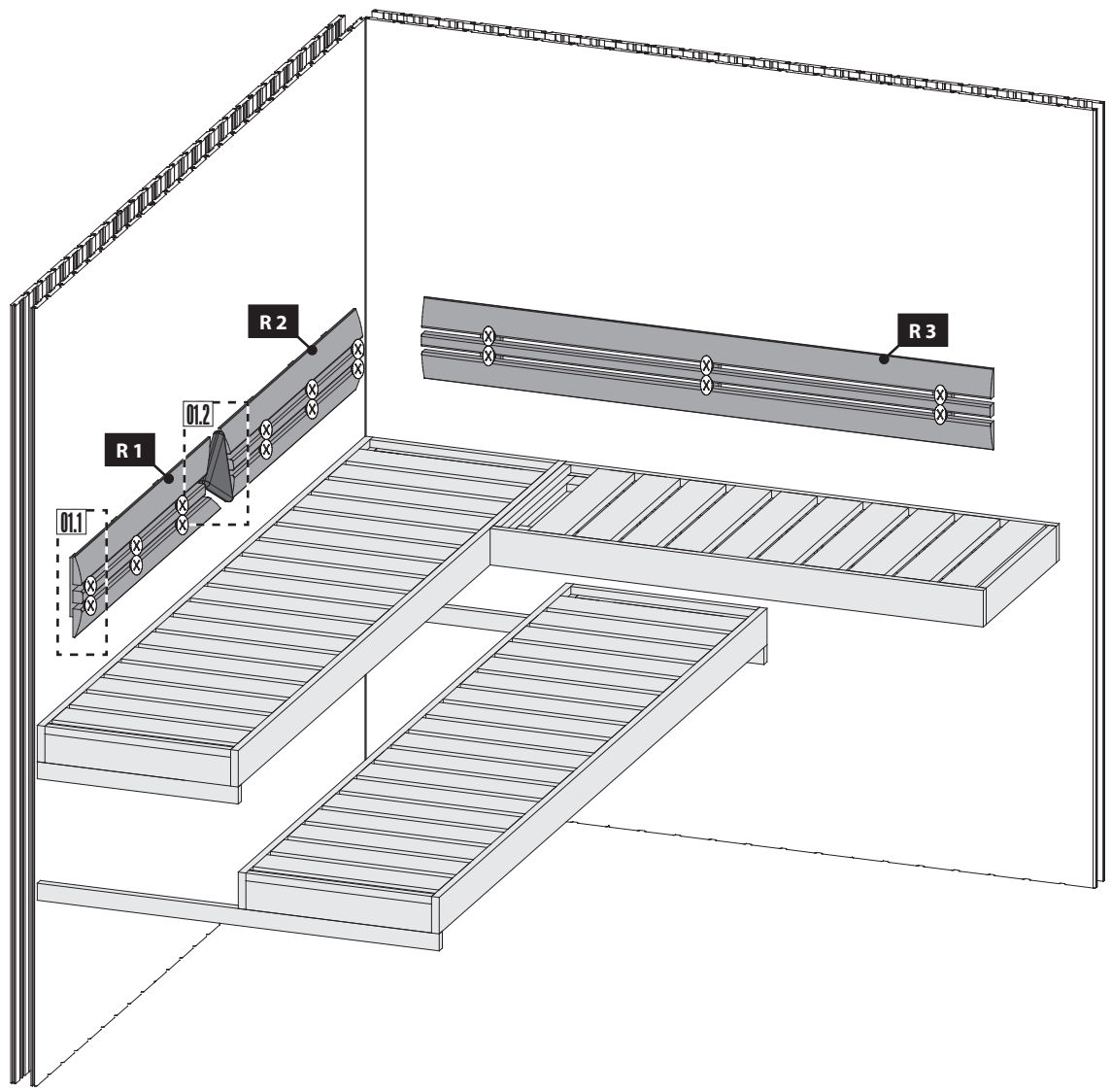

01.1

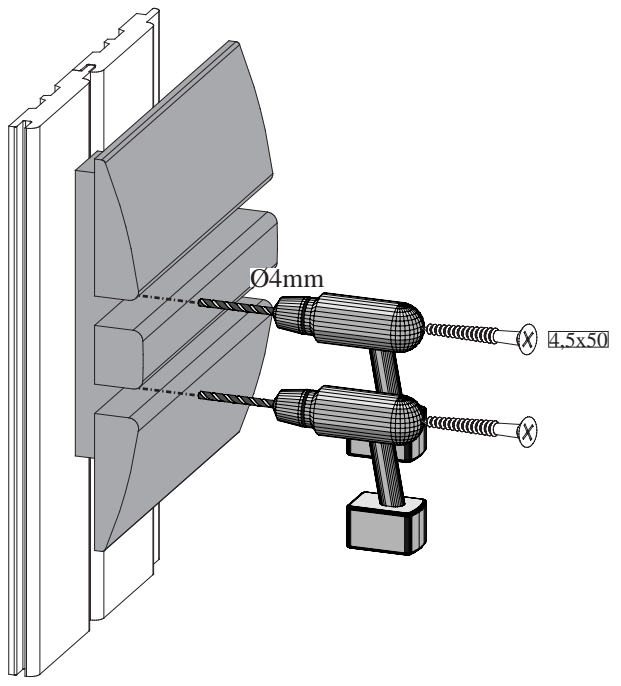

01.2

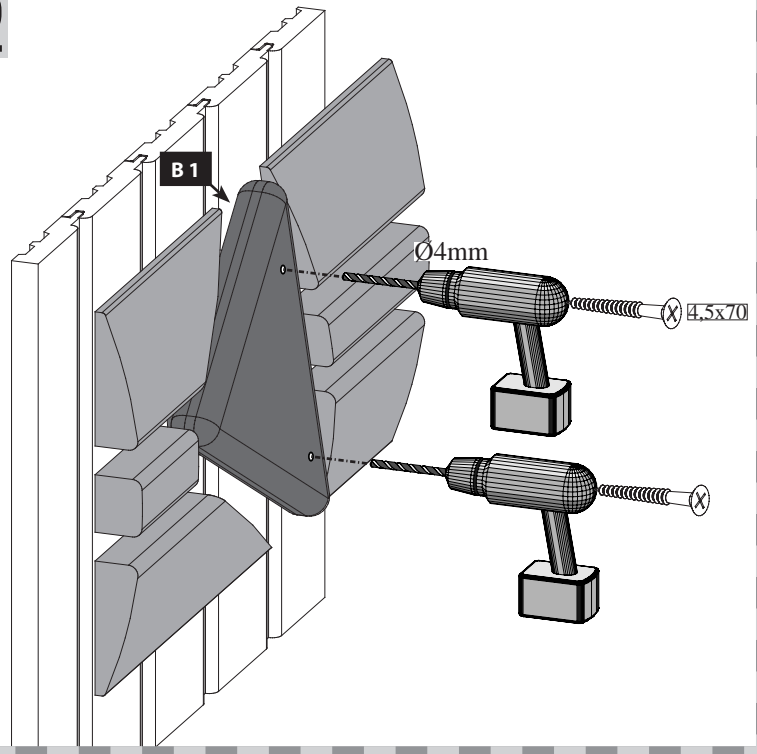

02



40616



 **Aufbauanleitung**

 **notice de montage**

 **Building Instructions**

 **montagehandleiding**

 **Instrucciones de construcción**

 **Istruzioni per il montaggio**

 **Service-Hotline: +49 421 38693 33**



Vergleichen Sie zuerst die Materialliste mit Ihrem Paketinhalt! Bitte haben Sie Verständnis, dass Beanstandungen nur im nicht aufgebauten Zustand bearbeitet werden können!



Commencez par comparer la liste du matériel avec le contenu de votre paquet! Sachez que nous traitons uniquement les réclamations concernant le matériel à l'état non monté!



First compare the list of materials with your package contents! Please understand that complaints can be processed in the non-built status only!



Vergelijk eerst de lijst van materialen met de inhoud van uw pakket! Reclamaties kunnen alleen in behandeling worden genomen zolang de onderdelen nog niet zijn gemonteerd!



En primer lugar, compare la lista de material con el contenido del paquete. Rogamos entienda que las reclamaciones sólo pueden ser tramitadas antes de montar el objeto!



Confrontate questa distinta materiali prima con il contenuto del pacchetto! Vi preghiamo di comprendere che eventuali reclami possono essere accolti solo prima del montaggio!



40616

5 x A1	2040 x 190 x 26mm	ID 26185
1 x A2	2040 x 190 x 26mm	ID 26190
1 x A3	2040 x 190 x 26mm	ID 26191
6 x B1	498 x 140 x 26mm	ID 26192
5 x B2	1014 x 140 x 26mm	ID 26193
1 x C1	498 x 30 x 30mm	ID 26198
70 x	4,5 x 60mm	ID 26199
70 x S3	4,5 x 30mm	ID 26116

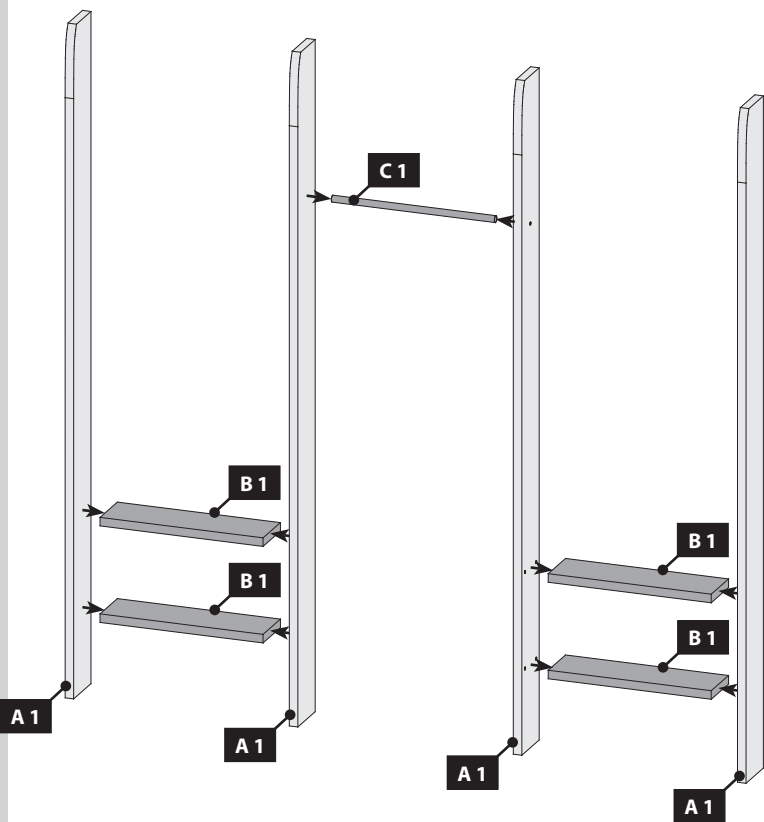
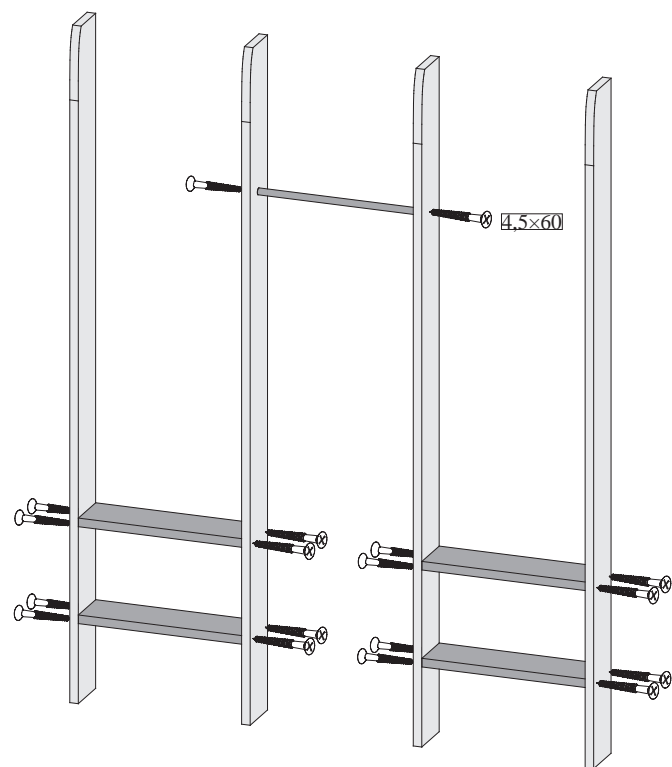
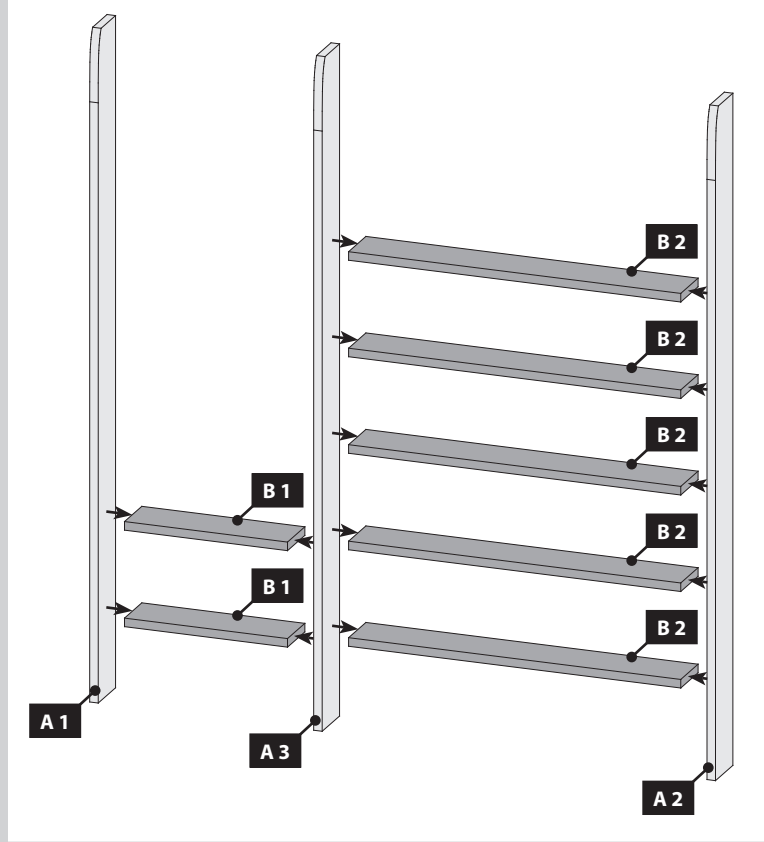
01**02****03****04****05**

06

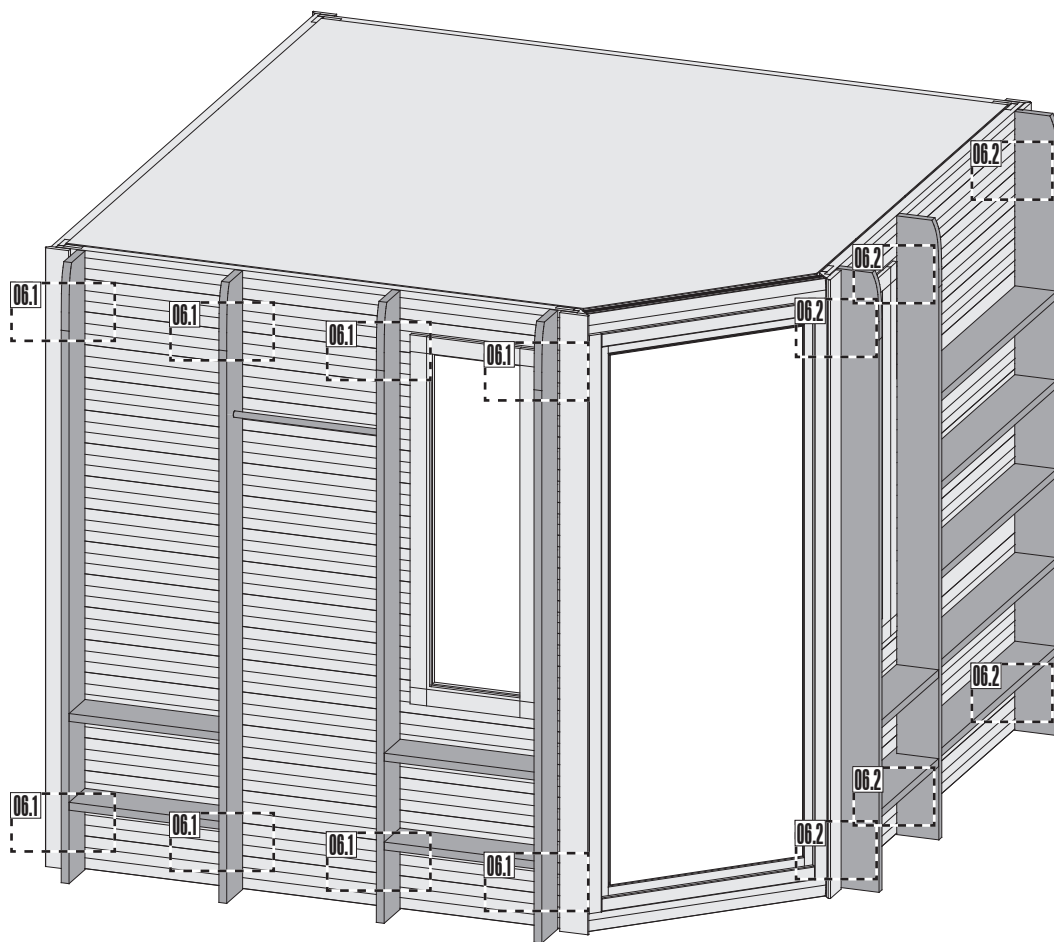

06.1

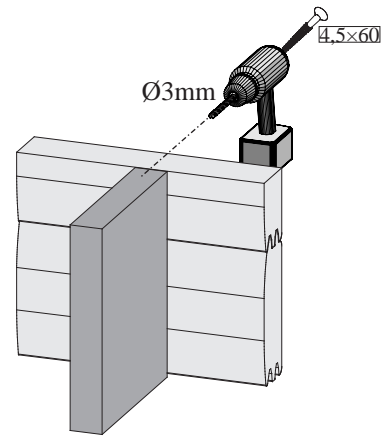

06.2

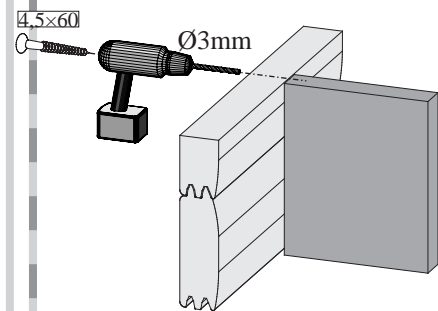

 Achten Sie beim Vorbohren immer auf bereits verlegte Elektroleitungen.

 Lors de percements préalables, faites toujours attention aux lignes électriques déjà posées.

 During pre-drilling, always make certain not to drill into preinstalled electrical cabling.

 Let bij het voorboren altijd op de reeds gelegde elektrische leidingen.

 Al pretaladrar, tenga en cuenta los conductos eléctricos ya tendidos.

 Prima di forare fare sempre attenzione alla presenza di cavi elettrici.